

Test report no.: <i>Prüfbericht-Nr.:</i>	CN23F6VN 001	Order No.: <i>Auftragsnr.:</i>	244491448 P00946847	Page 1 of 80 <i>Seite 1 von 80</i>
Client reference no.: <i>Kunden-Referenz-Nr.:</i>	1344616	Order date: <i>Auftragsdatum:</i>	2023-01-31	
Client: <i>Auftraggeber:</i>	SolaX Power Network Technology (Zhejiang) Co., Ltd. No. 288, Shizhu Road, Tonglu Economic Development Zone, Tonglu City, Zhejiang Province, 310000, P. R. China.			
Test item: <i>Prüfgegenstand:</i>	Lithium ion Rechargeable Battery System			
Identification / Type no.: <i>Bezeichnung / Typ-Nr.:</i>	T-BAT HS7.2, T-BAT HS10.8, T-BAT HS14.4, T-BAT HS18.0, T-BAT HS21.6, T-BAT HS25.2, T-BAT HS28.8, T-BAT HS32.4, T-BAT HS36.0, T-BAT HS39.6, T-BAT HS43.2, T-BAT HS46.8			
Order content: <i>Auftrags-Inhalt:</i>	CE-LVD			
Test specification <i>Prüfgrundlage:</i>	EN 62477-1:2012+A11:2014+A1:2017+A12:2021			
Date of sample receipt: <i>Wareneingangsdatum:</i>	2023-01-31			
Test sample no.: <i>Prüfmuster-Nr.:</i>	Engineering sample			
Testing period: <i>Prüfzeitraum:</i>	2023-03-02 - 2023-04-24			
Place of testing: <i>Ort der Prüfung:</i>	See page 5			
Testing laboratory: <i>Prüflaboratorium:</i>	TÜV Rheinland (Shanghai) Co., Ltd.			
Test result*: <i>Prüfergebnis*:</i>	Pass			
tested by: <i>geprüft von:</i>	<i>Scola Chen</i>			
Date: 2023-05-04 <i>Datum:</i>		Issue date: 2023-05-04 <i>Ausstellungsdatum:</i>		
Position / Stellung:	Scola Chen/PE	Position / Stellung:	Wilson Zhou/Authorizer	
Other: <i>Sonstiges:</i>	See the following pages for General product information and comment.			
Condition of the test item at delivery: <i>Zustand des Prüfgegenstandes bei Anlieferung:</i>	Test item complete and undamaged Prüfmuster vollständig und unbeschädigt			
* Legend:	P(ass) = passed a.m. test specification(s)	F(ail) = failed a.m. test specification(s)	N/A = not applicable	N/T = not tested
* Legende:	P(ass) = entspricht o.g. Prüfgrundlage(n)	F(ail) = entspricht nicht o.g. Prüfgrundlage(n)	N/A = nicht anwendbar	N/T = nicht getestet
This test report only relates to the above mentioned test sample. Without permission of the test center this test report is not permitted to be duplicated in extracts. This test report does not entitle to carry any test mark. <i>Dieser Prüfbericht bezieht sich nur auf das o.g. Prüfmuster und darf ohne Genehmigung der Prüfstelle nicht auszugsweise vervielfältigt werden. Dieser Bericht berechtigt nicht zur Verwendung eines Prüfzeichens.</i>				

V05

Test report no.: CN23F6VN 001
Prüfbericht-Nr.:

Page 2 of 80
Seite 2 von 80

Remarks
Anmerkungen

1	<p>The equipment used during the specified testing period was calibrated according to our test laboratory calibration program. The equipment fulfils the requirements included in the relevant standards. The traceability of the test equipment used is ensured by compliance with the regulations of our management system. Detailed information regarding test conditions, equipment and measurement uncertainty is available in the test laboratory and could be provided on request.</p> <p><i>Alle eingesetzten Prüfmittel waren zum angegebenen Prüfzeitraum gemäß eines festgelegten Kalibrierungsprogramms unseres Prüfhauses kalibriert. Sie entsprechen den in den Prüfprogrammen hinterlegten Anforderungen. Die Rückverfolgbarkeit der eingesetzten Prüfmittel ist durch die Einhaltung der Regelungen unseres Managementsystems gegeben.</i></p> <p><i>Detaillierte Informationen bezüglich Prüfkonditionen, Prüfequipment und Messunsicherheiten sind im Prüflabor vorhanden und können auf Wunsch bereitgestellt werden.</i></p>
2	<p>As contractually agreed, this document has been signed digitally only. TUV Rheinland has not verified and unable to verify which legal or other pertaining requirements are applicable for this document. Such verification is within the responsibility of the user of this document. Upon request by its client, TUV Rheinland can confirm the validity of the digital signature by a separate document. Such request shall be addressed to our Sales department. An environmental fee for such additional service will be charged.</p> <p><i>Wie vertraglich vereinbart, wurde dieses Dokument nur digital unterzeichnet. Der TÜV Rheinland hat nicht überprüft, welche rechtlichen oder sonstigen diesbezüglichen Anforderungen für dieses Dokument gelten. Diese Überprüfung liegt in der Verantwortung des Benutzers dieses Dokuments. Auf Verlangen des Kunden kann der TÜV Rheinland die Gültigkeit der digitalen Signatur durch ein gesondertes Dokument bestätigen. Diese Anfrage ist an unseren Vertrieb zu richten. Eine Umweltgebühr für einen solchen zusätzlichen Service wird erhoben.</i></p>
3	<p>Test clauses with remark of * are subcontracted to qualified subcontractors and described under the respective test clause in the report. Deviations of testing specification(s) or customer requirements are listed in specific test clause in the report.</p> <p><i>Prüfklausel mit der Note * wurden an qualifizierte Unterauftragnehmer vergeben und sind unter der jeweiligen Prüfklausel des Berichts beschrieben. Abweichungen von Prüfspezifikation(en) oder Kundenanforderungen sind in der jeweiligen Prüfklausel im Bericht aufgeführt.</i></p>
4	<p>The decision rule for statements of conformity, based on numerical measurement results, in this test report is based on the "Zero Guard Band Rule" and "Simple Acceptance" in accordance with ILAC G8:2019 and IEC Guide 115:2021, unless otherwise specified in the applied standard mentioned on Page 1 of this report or requested by the customer. This means that measurement uncertainty is not taken in account and hence also not declared in the test report. For additional information to the resulting risk based of this decision rule please refer to ILAC G8:2019.</p> <p><i>Die Entscheidungsregel für Konformitätserklärungen basierend auf numerischen Messergebnissen in diesem Prüfbericht basiert auf der "Null-Grenzwert-Regel" und der "Einfachen Akzeptanz" gemäß ILAC G8:2019 und IEC Guide 115:2021, es sei denn, in der auf Seite 1 dieses Berichts genannten angewandten Norm ist etwas anderes festgelegt oder vom Kunden gewünscht. Dies bedeutet, dass die Messunsicherheit nicht berücksichtigt wird und daher auch nicht im Prüfbericht angegeben wird. Zu weiteren Informationen bezueglich des Risikos durch diese Entscheidungsregel siehe ILAC G8:2019.</i></p>
5	



**TEST REPORT
IEC 62477-1
Safety requirements for power electronic converter systems
and equipment
Part 1: General**

Report Reference No..... : CN23F6VN 001
Date of issue : See cover page
Total number of pages : See cover page

**Name of Testing Laboratory
preparing the Report.....** : TÜV Rheinland (Shanghai) Co., Ltd.
 No. 177, Lane 777, West Guangzhong Road, Jing'an District,
 Shanghai 200072, P. R. China

Applicant's name : SolaX Power Network Technology (Zhe jiang) Co., Ltd.
Address : No. 288, Shizhu Road, Tonglu Economic Development Zone,
 Tonglu City, Zhejiang Province, 310000, P. R. China

TRF template used..... : IECEE OD-2020-F1:2020, Ed.1.3
Standard..... : IEC 62477-1: 2012, A1:2016
Test procedure..... : See cover page
Non-standard test method..... : N/A

Test Report Form No..... : IEC62477_1D
Test Report Form(s) Originator : VDE Prüf- und Zertifizierungsinstitut GmbH
Master TRF : Dated 2020-09-08

Copyright © 2020 IEC System of Conformity Assessment Schemes for Electrotechnical Equipment and Components (IECEE System). All rights reserved.

This publication may be reproduced in whole or in part for non-commercial purposes as long as the IECEE is acknowledged as copyright owner and source of the material. IECEE takes no responsibility for and will not assume liability for damages resulting from the reader's interpretation of the reproduced material due to its placement and context.

If this Test Report Form is used by non-IECEE members, the IECEE/IEC logo and the reference to the CB Scheme procedure shall be removed.

This report is not valid as a CB Test Report unless signed by an approved CB Testing Laboratory and appended to a CB Test Certificate issued by an NCB in accordance with IECEE 02.

General disclaimer:

The test results presented in this report relate only to the object tested.
 This report shall not be reproduced, except in full, without the written approval of the Issuing CB Testing Laboratory. The authenticity of this Test Report and its contents can be verified by contacting the NCB, responsible for this Test Report.

Test item description	Lithium ion Rechargeable Battery System	
Trade Mark		
Manufacturer	Same as applicant	
Model/Type reference	See cover page	
Ratings	See copy of marking label and model list.	
Responsible Testing Laboratory (as applicable), testing procedure and testing location(s):		
<input type="checkbox"/>	CB Testing Laboratory:	
Testing location/ address		
Tested by (name, function, signature)		
Approved by (name, function, signature) ...		
<input type="checkbox"/>	Testing procedure: CTF Stage 1:	
Testing location/ address		
Tested by (name, function, signature)		
Approved by (name, function, signature) ...		
<input type="checkbox"/>	Testing procedure: CTF Stage 2:	
Testing location/ address		
Tested by (name + signature)		
Witnessed by (name, function, signature) .:		
Approved by (name, function, signature) ...		
<input type="checkbox"/>	Testing procedure: CTF Stage 3:	
<input type="checkbox"/>	Testing procedure: CTF Stage 4:	
Testing location/ address		
Tested by (name, function, signature)		
Witnessed by (name, function, signature) .:		
Approved by (name, function, signature) ...		
Supervised by (name, function, signature) :		

List of Attachments (including a total number of pages in each attachment):

- Attachment 1: Photo Documentation (18 pages)
- Attachment 2: CDF (8 pages)

Summary of testing:
Tests performed (name of test and test clause):

Clause(s)	Test(s)
5.2.2.1	Clearance and creepage distances
5.2.2.2	Non-accessibility test
5.2.2.3	Ingress protection test (IP rating)
5.2.2.4.2.3	Steady force test, 250 N
5.2.2.5	Stability test
5.2.2.7	Handles and manual controls securement test
5.2.3.2	Impulse voltage
5.2.3.4	a.c or d.c voltage test
5.2.3.10	Temperature rise
5.2.3.11	Protective equipotential bonding test
5.2.4.4	Output short-circuit test
5.2.4.6	Breakdown of components
5.2.5.3	Glow-wire test
5.2.6.3.1	Dry heat
5.2.6.3.2	Damp heat
5.2.6.4	Vibration test

Testing location:

SolaX Power Network Technology (Zhe jiang) Co., Ltd.

No. 288, Shizhu Road, Tonglu Economic Development Zone, Tonglu City, Zhejiang Province, 310000, P. R. China

Summary of compliance with National Differences (List of countries addressed):

EU

The product fulfils the requirements of IEC 62477-1:2012+A1:2016, EN 62477-1:2012+A11:2014+A1:2017+A12:2021

Statement concerning the uncertainty of the measurement systems used for the tests

(may be required by the product standard or client)

Internal procedure used for type testing through which traceability of the measuring uncertainty has been established:

Procedure number, issue date and title:

Calculations leading to the reported values are on file with the NCB and testing laboratory that conducted the testing.

Statement not required by the standard used for type testing

(Note: When IEC or ISO standard requires a statement concerning the uncertainty of the measurement systems used for tests, this should be reported above. The informative text in parenthesis should be delete in both cases after selecting the applicable option)

Copy of marking plate:

The artwork below may be only a draft. The use of certification marks on a product must be authorized by the respective NCBs that own these marks.

TRIPLE POWER

Model: TBMS-MCS0800

Operating Voltage	90-750 Vdc
Max. Charge/Discharge Current	50 A
Operating Temperature Range	-30°C~+70°C
Ingress Protection	IP65



SolaX Power Network Technology (Zhejiang) CO., LTD.

Add.: No. 288, Shizhu Road, Tonglu Economic Development Zone, Tonglu City, Zhejiang Province, 310000 P.R. CHINA

Tel.: +86 (0) 571-5626 0011 E-mail: info@solaxpower.com
www.solaxpower.com

MADE IN CHINA
320201094501

Label for master control of battery system

TRIPLE POWER

SN: [Redacted]

IFP/41/150/112/[165]nS[M]-30+60/95

Model: TP-HS36

Battery Type: LiFePO4	Nominal Charge/Discharge Current	35 A
Nominal Voltage 51.2 Vdc	Max. Charge/Discharge Current	50 A
Nominal Capacity 72 Ah	Charge Temperature	-30~+53°C ① / 0~+53°C ②
Nominal Energy 3.686 kWh	Discharge Temperature	-30~+53°C ① / -20~+53°C ②
Ingress Protection IP65	Storage Temperature	-20~+50°C (3 months) 10~+40°C (1 year)

CM A ① Build-in heating function ② No heating function



DANGER

- Do not short circuit the battery modules.
- Keep out of reach of children or pets.
- Do not insert unrelated objects into any part of the battery modules.
- Do not impact, pull, drag, sit, step or put heavy things on battery modules.
- Do not attempt to open, disassemble, repair, tamper with, or modify the battery modules.
- Avoid of direct sunlight, moisture or liquid.
- Follow the product manual to make wiring connection. Must be operated by qualified professionals.
- Recharge battery at least every 3 months (incl. when in storage).
- Contact your supplier within 24 hours if anything failure happen.

SolaX Power Network Technology (Zhejiang) Co., Ltd.

Tel.: +86 (0) 571-5626 0011 E-mail: info@solaxpower.com
www.solaxpower.com

MADE IN CHINA
320201094302

Label for Slave control of battery system

TRIPLE POWER

Lithium-ion Rechargeable Battery System

Product Name: T-BAT-SYS-HV-S2.5 T-BAT-SYS-HV-S3.6

Battery Type: LiFePO4

Rated Capacity: 50 Ah 72 Ah

Model No./Nominal Voltage/Rated Capacity

T-BAT HS2.5*n/51.2*n Vdc/2.56*n kWh
IFpP/14/125/280/[165]nS[M]-20+60/95 (2≤n≤13)
Max. Short-circuit Current: 1900 A
Max. Charge/Discharge Current: 45 A

T-BAT HS3.6*n/51.2*n Vdc/3.686*n kWh
IFpP/41/150/112/[165]nS[M]-30+60/95 (2≤n≤13)
Max. Short-circuit Current: 1850 A
Max. Charge/Discharge Current: 50 A

Charge Temperature: -30~+53°C ① / 0~+53°C ②
Discharge Temperature: -30~+53°C ① / -20~+53°C ②
Storage Temperature: -20°C~+50°C (3 months)
+10°C~+40°C (1 year)

Altitude: Below 3000 m

On heating function Off heating function

Ingress Protection: IP65
Protection Class: I
Certified to IEC 62619/EN 62619



SN: [Redacted]

SolaX Power Network Technology (Zhejiang) Co., Ltd.

Add.: No. 288, Shizhu Road, Tonglu Economic Development Zone, Tonglu City, Zhejiang Province, 310000 P.R. CHINA

Tel.: +86 (0) 571-5626 0011 E-mail: info@solaxpower.com www.solaxpower.com

MADE IN CHINA
320201094401

Label for battery system

Test item particulars	
Classification of installation and use	Protective class I
Supply Connection	Not directly connected to the mains
.....	
Possible test case verdicts:	
- test case does not apply to the test object..... : N/A	
- test object does meet the requirement..... : P (Pass)	
- test object does not meet the requirement..... : F (Fail)	
Testing	
Date of receipt of test item : See cover page	
Date (s) of performance of tests	
..... : See cover page	
General remarks:	
"(See Enclosure #)" refers to additional information appended to the report. "(See appended table)" refers to a table appended to the report.	
Throughout this report a <input type="checkbox"/> comma / <input checked="" type="checkbox"/> point is used as the decimal separator.	
Manufacturer's Declaration per sub-clause 4.2.5 of IEC 60335-1:	
The application for obtaining a CB Test Certificate includes more than one factory location and a declaration from the Manufacturer stating that the sample(s) submitted for evaluation is (are) representative of the products from each factory has been provided:	<input type="checkbox"/> Yes <input checked="" type="checkbox"/> Not applicable
When differences exist; they shall be identified in the General product information section.	
Name and address of factory (ies): SolaX Power Network Technology (Zhejiang) Co., Ltd. No. 288, Shizhu Road, Tonglu Economic Development Zone, Tonglu City, Zhejiang Province, 310000, P. R. China.	
General product information and other remarks:	
<u>Product Description:</u>	
The product include 12 type designations in model series of Lithium ion Rechargeable Battery System, which includes one master BMS and several battery modules in series connection. In each battery module, there are 16 cells in series connection. The Battery system has 12 type designations according to the quantity of battery modules connection in series from 2 to 13 pcs. The function of master control unit is the battery management system. The master control unit gets the signal and data information of cell voltage and temperature through the sampling ports. The IP rating of the Lithium ion Rechargeable Battery System is IP65 and the Pollution Degree is considered as PD 2 inside, which specified by the manufacturer. The insulation between the DC (Battery) power circuit and the metal enclosure is basic insulation (BI) and the one between the DC (Battery) power circuit and communication circuit is reinforced insulation (RI) or double insulation (DI).	

This battery system contains heating films in battery modules. The closing and opening of the heating function will be set through the IPC or inverter.

- When the heating function state was off:
 - The battery system charging temperature range is: 0 to 53°C; discharging temperature range is -20 to 53°C
- 1. When the heating function state was on:
 1. Cell actual operate temperature range: charging temperature: 0 to 53°C; discharging temperature: -20 to 53°C
 2. Outside ambient temperature range: charging temperature: -30 to 53°C; discharging temperature: -30 to 53°C
 3. During charging: when temperature range is -30~0°C, the heating film will heating cells until cell temperature reach to 2°C, then the heating will stop work
 4. During discharging: when temperature range is -30~-20°C, the heating film will heating cells until cell temperature reach to -18°C, then the heating will stop work.
 5. One battery module has four heating films, and all of the films was connect in series. The heating films will take power from inverter, and the voltage is the same with the maximum voltage of the battery system.

Note: The heating function of battery system was declare and verified by client.

The system block diagram is outlined as below.

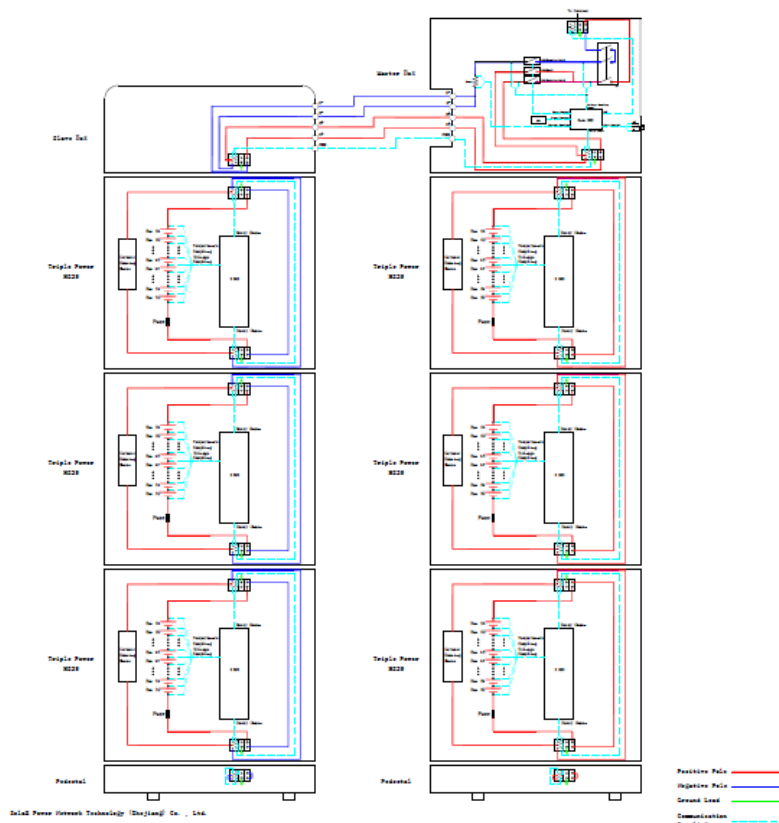

Additional test item particulars	
Equipment mobility	<input type="checkbox"/> movable <input type="checkbox"/> hand-held <input checked="" type="checkbox"/> stationary <input type="checkbox"/> fixed <input type="checkbox"/> transportable <input type="checkbox"/> for building-in
Environmental category	<input type="checkbox"/> indoor unconditional <input type="checkbox"/> indoor conditional <input checked="" type="checkbox"/> outdoor
Connection to the mains	<input type="checkbox"/> pluggable equipment <input type="checkbox"/> direct plug-in <input type="checkbox"/> permanent connection <input type="checkbox"/> for building-in Not directly connected to the mains
Over voltage category (mains)	<input type="checkbox"/> OVC I <input type="checkbox"/> OVC II <input type="checkbox"/> OVC III <input type="checkbox"/> OVC IV Not directly connected to the mains
Over voltage category (battery)	<input type="checkbox"/> OVC I <input checked="" type="checkbox"/> OVC II <input type="checkbox"/> OVC III <input type="checkbox"/> OVC IV
Mains supply tolerance (%)	N/A
Tested for power systems (%)	N/A
IT testing, phase-phase voltage (V)	N/A
Class of equipment	<input checked="" type="checkbox"/> Class I <input type="checkbox"/> Class II <input type="checkbox"/> Class III <input type="checkbox"/> Not classified
Mass of equipment (kg)	See General product information for details
Pollution degree	<input type="checkbox"/> PD 1 <input checked="" type="checkbox"/> PD2 (Inside) <input type="checkbox"/> PD 3
IP protection class	IP65

IEC 62477-1			
Clause	Requirement – Test	Result – Remark	Verdict

Model list:

T-BAT-SYS-HV-S3.6													
Product name	Li-ion cell	Lithium ion Rechargeable Battery System											
Battery Type	72Ah (LFP) cell												
Type/model	CB59	T-BAT HS7.2	T-BAT HS10.8	T-BAT HS14.4	T-BAT HS18.0,	T-BAT HS21.6	T-BAT HS25.2	T-BAT HS28.8	T-BAT HS32.4,	T-BAT HS36.0	T-BAT HS39.6,	T-BAT HS43.2	T-BAT HS46.8
Component	-	TBMS-MCS080 0*1 + TP-HS36 *2	TBMS-MCS080 0*1 + TP-HS36 *3	TBMS-MCS080 0*1 + TP-HS36 *4	TBMS-MCS080 0*1 + TP-HS36 *5	TBMS-MCS080 0*1 + TP-HS36 *6	TBMS-MCS080 0*1 + TP-HS36 *7	TBMS-MCS080 0*1 + TP-HS36 *8	TBMS-MCS080 0*1 + TP-HS36 *9	TBMS-MCS080 0*1 + TP-HS36 *10	TBMS-MCS0800* 1 + TP-HS36 *11	TBMS-MCS0800* 1 + TP-HS36 *12	TBMS-MCS0800* 1 + TP-HS36 *13
Nominal Voltage [V]	3.2	102.4	153.6	204.8	256.0	307.2	358.4	409.6	460.8	512.0	563.2	614.4	665.6
Operating Voltage Range [V]	2.5 to 3.65	90-116	135-174	180-232	225-290	270-349	315-406	360-465	405-522	450-580	495-636	540-695	585-750
Battery Module 1P16S = 1 Module)	-	2	3	4	5	6	7	8	9	10	11	12	13
Rated Capacity [Ah]	72	72											
Total Storage Energy [kWh]	-	7.37	11.06	14.75	18.43	22.12	25.80	29.49	33.18	36.86	40.55	44.24	47.92
Standard Power [kW]	-	3.58	5.38	7.17	8.96	10.75	12.54	14.34	16.13	17.92	19.71	21.50	23.30
Max. Power [kW]	-	5.12	7.68	10.24	12.80	15.36	17.92	20.48	23.04	25.60	28.16	30.72	33.28
Nominal Current [A]	36	35											
Maximum Charging Current [A]	72	50											
Maximum Discharging Current [A]	144	50											
Charge Temperature Range temperature [°C]	-10 to 60	0 to 53 (Off heating function) -30 to 53 (On heating function)											
Discharge Temperature Range temperature [°C]	-20 to 60	-20 to 53 (Off heating function) -30 to 53 (On heating function)											
Storage Temperature [°C]	-30 to 60	-20°C to 50°C (3 months) 10°C to 40°C (1 year)											
Dimension (L x W x H) [mm]	(39.72±1))*(148.6 6±1)*(11 0.01±1) mm	TBMS-MCS0800: 510*365*157, TP-HS36: 510*365*152, Pedestal:510*365*90, Series Box: 510*365*157											
Weight [kg]	1.38±0.1 5kg	13kg+34 kg*2+9k g	13kg+34 kg*3+9k g	13kg+34 kg*4+9k g	13kg+34 kg*5+9k g	13kg+34 kg*6+9k g	13kg+34 kg*7+9k g	13kg+34 kg*8+9k g	13kg+34 kg*9+9k g	13kg+34 kg*10+1 0kg+18k g	13kg+34kg *11+10kg+ 18kg	13kg+34kg *12+10kg+ 18kg	13kg+34kg *13+10kg+ 18kg
Installation	-	Stackable level package											
Enclosure Protection (IP)	-	IP65											
Cooling Type	-	Natural cooling											
Altitude [m]	-	Below 3000											

IEC 62477-1			
Clause	Requirement – Test	Result – Remark	Verdict
4	PROTECTION AGAINST HAZARDS		P
4.1	General		P
4.2	Fault and abnormal conditions	See Table 4.2 to 4.3	P
	Components in 4.2 also include insulation systems, ports, etc (IEC 62477-1:2012/AMD1:2016)		P
4.3	Short-circuit and overcurrent protection	See Table 4.2 to 4.3	P
4.3.1	General	No hazards under short circuit or overload conditions at any port.	P
4.3.2	Specification of prospective short-circuit current		P
4.3.2.1	General		P
	The interrupting capability of the overcurrent protective device shall be equal or greater than the prospective short circuit current of the mains supply.		P
	For pluggable equipment type A, either the PECS shall be designed so that the building installation provides short circuit backup protection, or additional short circuit backup protection shall be provided as part of the equipment.	See below	N/A
	For permanently connected equipment or pluggable equipment type B, it is permitted for short circuit backup protection to be in the building installation.	Considered	P
4.3.2.2	Specification of the rated conditional short-circuit current (I_{cc}) on input ports (IEC 62477-1:2012/AMD1:2016)		P
	In case the PECS manufacturer selects the conditional short-circuit current (I_{cc}) rating according to 4.3.1, the following specified: (IEC 62477-1:2012/AMD1:2016)		P
	- conditional short-circuit current (I_{cc}), (IEC 62477-1:2012/AMD1:2016)		P
	- characteristics of the short-circuit protective device, and (IEC 62477-1:2012/AMD1:2016)		P
	- minimum required prospective short-circuit current ($I_{cp,mr}$) (IEC 62477-1:2012/AMD1:2016)		P
	If it is shown by analysis that the result of one test is representative of the worst case, less severe combinations need not be tested. (IEC 62477-1:2012/AMD1:2016)		P
4.3.2.3	Output short circuit current ability		P
	The output short circuit current ratings apply to a.c. and d.c. power output ports and to other ports for which overcurrent protection is necessary. For all output ports, short circuit evaluation to determine the minimum and maximum output short circuit current shall be performed according to 5.2.4.4 and the output short circuit current available		P

IEC 62477-1			
Clause	Requirement – Test	Result – Remark	Verdict
	<p>from the PECS shall be specified as in 5.2.4.4 and 6.2.</p> <p>Internal electronic output short circuit protection is considered acceptable as an output short circuit protection device of the PECS, when compliance is shown by test in 5.2.4.4.</p>		
4.3.2.4	Combined input and output ports		P
	For ports which are both input and output ports the applicable requirements of both 4.3.2.1 and 4.3.2.3 apply.		P
4.3.3	Short-circuit coordination (backup protection)		P
	<p>Protective devices provided or specified shall have adequate breaking capability to interrupt the maximum prospective short circuit current specified for the port to which they are connected.</p> <p>If internal protection of the PECS is not rated for the prospective short circuit current, the installation instructions shall specify an upstream protective device, rated for this prospective short circuit current of that port, which shall be used to provide backup protection. Analysis shall ensure the protection coordination between the external and internal protective device.</p>		P
	Compliance shall be checked by inspection and by the tests of 5.2.4.4 and 5.2.4.5.		P
4.3.4	Protection by several devices		P
	<p>Where protective devices that require manual replacement or resetting are used in more than one pole of a supply to a given load, those devices shall be located together. It is permitted to combine two or more protective devices in one component.</p> <p>Compliance shall be checked by inspection.</p>		P
4.3.5	Input ports short time withstand current, I_{cw} (IEC 62477-1:2012/AMD1:2016)		N/A
	In case the PECS manufacturer selects the short time withstand current (I_{cw}) rating according to 4.3.1, the following specified: (IEC 62477-1:2012/AMD1:2016)		P
	- rated short time withstand current (I_{cw}), (IEC 62477-1:2012/AMD1:2016)		N/A
	- associated duration, and (IEC 62477-1:2012/AMD1:2016)		N/A
	- rated peak withstand current (I_{pk}). (IEC 62477-1:2012/AMD1:2016)		N/A
	If it is shown by analysis that the result of one test is representative of the worst case, less severe combinations need not be tested. (IEC 62477-1:2012/AMD1:2016)		N/A
4.4	Protection against electric shock		P

IEC 62477-1			
Clause	Requirement – Test	Result – Remark	Verdict
4.4.1	General		P
4.4.2	Decisive voltage classification		P
4.4.2.1	General	Considered	P
4.4.2.2	Determination of decisive voltage class		
4.4.2.2.1	General		P
	For protection against the ventricular fibrillation body reaction, DVC can be selected from Table 2.		P
4.4.2.2.2	Selection tables for contact area and skin humidity condition		P
	In order to protect against ventricular fibrillation, the appropriate conditions from Table 3 and Table 4 shall be selected.		P
4.4.2.2.3	Limits of the working voltage for the DVC		P
4.4.2.3	Requirements for protection against electric shock		P
4.4.3	Provision for basic protection		P
4.4.3.1	General	Considered	P
4.4.3.2	Protection by means of insulation of live parts	Considered	P
	Live parts shall be completely surrounded with insulation if their working voltage is greater than DVC As or if they do not have protective separation from adjacent circuits of DVC C.		P
	Basic insulation may be provided by solid insulation or air clearance.		P
	The insulation shall be rated according to the impulse voltage, temporary overvoltage or working voltage (see 4.4.7.2.1), whichever gives the most severe requirement. It shall not be possible to remove the insulation without the use of a tool or key.		P
4.4.3.3	Protection by means of enclosures or barriers	Considered	P
	Live parts with voltage higher than DVC As shall be: - arranged in enclosures or located behind enclosures or barriers, which meet at least the requirements of the Protective Type IPXXB according to Clause 7 of IEC 60529:1989; - located at the top surfaces of enclosures or barriers which are accessible when the equipment is energized shall meet at least the requirements of the protective type IP3X with regard to vertical access only.	IP65	P
	For moveable equipment with no defined top and bottom this requirement of protective Type IP3X applies to all sides.		N/A
	If the PECS is installed in a restricted access area, IPXXB instead of IP3X applies.		N/A

IEC 62477-1			
Clause	Requirement – Test	Result – Remark	Verdict
	Product committees using this document as reference document might consider less requirement for equipment having openings in the top of an enclosure with a height exceeding 1,8 m.		N/A
	Compliance is shown by test of 5.2.2.2.		P
	It shall only be possible to open enclosures or remove barriers: <ul style="list-style-type: none"> • with the use of a tool or key; or • after de-energization of these live parts. 		P
	Where the enclosure is required to be opened and the PECS energized during installation or maintenance: <ol style="list-style-type: none"> accessible live parts of voltage higher than DVC As shall be protected by at least IPXXA; live parts of voltage higher than DVC As that are likely to be touched when making adjustments shall be protected by at least IPXXB; it shall be ensured that persons are aware that live parts with voltage higher than DVC As are accessible. 	Safety Precautions during operation and use provided in product manual. It is not allow maintenance and repairing to be performed by unqualified personnel	P
4.4.3.4	Protection by means of limitation of touch current and charge		N/A
	The limitation of touch current and discharge energy shall not exceed: <ul style="list-style-type: none"> - a value of 3,5 mA a.c. or 10 mA d.c. for the limitation of touch current; and - a value of 50 μC for the limitation of discharge energy. 		N/A
4.4.3.5	Protection by means of limited voltages		P
	The voltage between simultaneously accessible parts shall not be greater than DVC As as determined in 4.4.2.2.	The communication circuit considered as DVC A circuit.	P
4.4.4	Provision for fault protection		P
4.4.4.1	General		P
	Fault protection shall be provided by one or more of the following measures: <ul style="list-style-type: none"> • Protective equipotential bonding in 4.4.4.2 in combinations with the PE conductor in 4.4.4.3; • Automatic disconnection of supply in 4.4.4.4; • Supplementary insulation in 4.4.4.5; • Simple separation between circuits in 4.4.4.6; • Electrically protective screening in 4.4.4.7. Fault protection shall be independent and additional to those for basic protection.		P
4.4.4.2	Protective equipotential bonding		P

IEC 62477-1			
Clause	Requirement – Test	Result – Remark	Verdict
4.4.4.2.1	General		P
	<p>Protective equipotential bonding shall be provided between accessible conductive parts of the equipment and the means of connection for the PE conductor, except:</p> <ul style="list-style-type: none"> a) accessible conductive parts that are protected by one of the measures in 4.4.6.4; or b) when accessible conductive parts are separated from <i>live parts</i> using <i>double</i> or <i>reinforced insulation</i>. 		P
	<p>Electrical contact to the means of connection of the PE conductor shall be achieved by one or more of the following means:</p> <ul style="list-style-type: none"> • through direct metallic contact; • through other accessible conductive parts or other metallic components which are not removed when the PECS is used as intended; • through a dedicated protective equipotential bonding conductor. 		P
4.4.4.2.2	Rating of protective equipotential bonding		P
	<p>Protective equipotential bonding shall either be:</p> <ul style="list-style-type: none"> a) sized in accordance with the requirements for the PE conductor in 4.4.4.3 and the means of connection for the PE conductor in 4.4.4.3.2 to ensure no voltage drop exceeding the values from 4.4.2.2.3 during a fault; or b) sized <ul style="list-style-type: none"> • to withstand the highest stresses that can occur to the PECS item(s) concerned when they are subjected to a fault connecting to accessible conductive parts; and • to remain effective for as long as a fault to the accessible conductive parts persists or until an upstream protective device removes power from the part; and • to ensure no voltage drop exceeding the values from 4.4.2.2.3 during normal operation and during a fault. <p>Compliance shall be checked with the type tests in 5.2.3.11</p>		P
4.4.4.3	PE conductor		P
4.4.4.3.1	General		P
	<p>A PE conductor shall be connected at all times when power is supplied to the PECS, unless the PECS complies with the requirements of protective class II (see 4.4.6.3) or protective class III. Unless local wiring regulations state otherwise, the PE conductor cross-sectional area shall be determined from Table 7 or by calculation according to 543.1 of</p>		P

IEC 62477-1			
Clause	Requirement – Test	Result – Remark	Verdict
	IEC 60364-5-54:2011.		
	If the PE conductor is routed through a plug and socket, or similar means of disconnection, it shall not be possible to disconnect it unless power is simultaneously removed from the part to be protected.		N/A
	The cross-sectional area of every PE conductor that does not form part of the supply cable or cable enclosure shall, in any case, be not less than: <ul style="list-style-type: none"> • 2,5 mm² if mechanical protection is provided; or • 4 mm² if mechanical protection is not provided. 	Larger than 4 mm ²	P
	Provisions within cord-connected equipment shall be made so that the PE conductor in the cord shall, in the case of failure of the strain-relief mechanism, be the last conductor to be interrupted. For special system topologies, the PECS designer shall verify the PE conductor cross-section required.		P
4.4.4.3.2	Means of connection for the PE conductor		P
	PECS shall have a means of connection for the PE conductor, located near the terminals for the respective live conductors. The means of connection shall be corrosion-resistant and shall be suitable for the connection of conductors according to Table 7 and of cables in accordance with the wiring rules applicable at the installation. The means of connection for the PE conductor shall not be used as a part of the mechanical assembly of the equipment or for other connections. Connection and bonding points shall be designed so that their current-carrying capacity is not impaired by mechanical, chemical, or electrochemical influences. Where enclosures and/or conductors of aluminium or aluminium alloys are used, particular attention should be given to the problems of electrolytic corrosion. Compliance shall be checked by inspection.		P
4.4.4.3.3	Touch current in case of failure of PE conductor		N/A
	For all other PECS, one or more of the following measures shall be applied, unless the touch current can be shown to be less than the limits specified in 4.4.3.4: <ol style="list-style-type: none"> a) Use of a fixed connection and <ul style="list-style-type: none"> • a cross-section of the PE conductor of at least 10 mm² Cu or 16 mm² Al; or • automatic disconnection of the supply in case of discontinuity of the PE conductor; or • provision of an additional terminal for a second PE conductor of the same 		N/A

IEC 62477-1			
Clause	Requirement – Test	Result – Remark	Verdict
	<p>cross-sectional area as the original PE conductor;</p> <p>or</p> <p>b) Use of a pluggable type B connection with a minimum PE conductor cross-section of 2,5 mm² as part of a multi-conductor power cable. Adequate strain relief shall be provided.</p>		
	Compliance is checked by inspection and by test of 5.2.3.7.		N/A
4.4.4.4	Automatic disconnection of supply	No such part	N/A
	<p>For automatic disconnection of supply:</p> <ul style="list-style-type: none"> • a protective equipotential bonding system shall be provided; and • a protective device operated by the fault current shall disconnect one or more of the line conductors supplying the equipment, system or installation, in case of a failure of basic insulation. <p>The protective device shall interrupt the fault current within a time as specified in Figure 1, Figure 2 or Figure 3 in 4.4.2.2.3.</p>		N/A
4.4.4.5	Supplementary insulation		P
4.4.4.6	Simple separation between circuits	Considered	P
	<p>If any component is connected between the separated circuits, that component shall withstand the electric stresses specified for the insulation which it bridges.</p> <p>If any component is connected between a circuit and a circuit connected to earth, its impedance shall limit the current flow through the component to the steady-state touch current values indicated in 4.4.3.4.</p>		P
4.4.4.7	Electrically protective screening		N/A
	<p>Electrically protective screening interposed between hazardous live parts of a PECS, shall consist of a conductive screen connected to the protective equipotential bonding of the PECS whereby the screen is separated from live parts by at least simple separation.</p> <p>The protective screen and the connection to the protective equipotential bonding system of the PECS and that interconnection shall comply with the requirements of 4.4.4.2.</p>		N/A
4.4.5	Enhanced protection		P
4.4.5.1	General		P
	<p>Enhanced protection shall provide both basic and fault protection and can be achieved by means of:</p> <ul style="list-style-type: none"> • Reinforced insulation in 4.4.5.2; • Protective separation between circuits in 4.4.5.3; 		P

IEC 62477-1			
Clause	Requirement – Test	Result – Remark	Verdict
	• Protection by means of in 4.4.5.4.		
4.4.5.2	Reinforced insulation		P
	Reinforced insulation shall be so designed as to be able to withstand electric, thermal, mechanical and environmental stresses with the same reliability of protection as provided by double insulation. (basic insulation and supplementary insulation, see 4.4.3.2 and 4.4.4.5)	Between DC power circuit and communication circuit.	P
4.4.5.3	Protective separation between circuits		P
	Protective separation between a circuit and other circuits shall be achieved by one of the following means: <ul style="list-style-type: none"> • double insulation (basic insulation and supplementary insulation in 4.4.3.2 and 4.4.4.5); • reinforced insulation in 4.4.5.2; • electrically protective screening in 4.4.4.7; • a combination of these provisions. 	Between DC power circuit and communication circuit.	P
	If conductors of the separated circuit are contained together with conductors of other circuits in a multi-conductor cable or in another grouping of conductors, they shall be insulated, individually or collectively, for the highest voltage present, so that double insulation is achieved. If any component is connected between the separated circuits, that component shall comply with the requirements for protective impedance devices (see 4.4.5.4)		P
4.4.5.4	Protection by means of protective impedance		N/A
	Protective impedance shall be arranged so that under both normal and single fault conditions the current and discharge energy available shall be limited according to 4.4.3.4.		N/A
	The protective impedances shall be designed and tested to withstand the impulse voltages and temporary overvoltages for the circuits to which they are connected. See 5.2.3.2 and 5.2.3.4 for tests.		N/A
	Compliance with the requirement for the limitation of touch current is checked by test of 5.2.3.6.		N/A
	Compliance with the requirement for the discharge energy shall be checked by performing calculations and/or measurements to determine the voltage and capacitance. NOTE A protective impedance designed according to this subclause is not considered to be a galvanic connection.		N/A
4.4.6	Protective measures		P
4.4.6.1	General		P

IEC 62477-1			
Clause	Requirement – Test	Result – Remark	Verdict
4.4.6.2	Protective measures for protective class I equipment		P
	Protective class I equipment shall meet the requirements for: <ul style="list-style-type: none"> • basic protection in 4.4.3; and • fault protection in 4.4.4.2 and 4.4.4.3 with respect to equipotential bonding and PE conductor. 		P
4.4.6.3	Protective measures for protective class II equipment	Class I equipment	N/A
	<p>Protective class II equipment shall meet the requirements for enhanced protection according to 4.4.5 and the enclosure shall meet the requirement for basic protection in 4.4.3 with respect to accessibility to hazardous live parts.</p> <p>Protective class II equipment shall not have means of connection for the PE conductor. This does not apply if a PE conductor is passed through the equipment to equipment series-connected beyond it.</p> <p>In the latter case the PE conductor and its means for connection shall be separated from:</p> <ul style="list-style-type: none"> • accessible surface of the equipment; and • circuits which employ protective separation with at least simple separation according to the requirement in 4.4.4.6. <p>The simple separation shall be designed according to the rated voltage of the series-connected equipment.</p> <p>Equipment of protective class II may have provision for the connection of an earthing conductor for functional reasons or for the damping of overvoltages. In this case, the functional earthing conductor shall be separated from:</p> <ul style="list-style-type: none"> • accessible surface of the equipment; and • circuits which employ protective separation according to 4.4.5.3 <p>with at least protective separation according to the requirement in 4.4.5.3.</p> <p>Equipment of protective class II shall be marked according to 6.3.7.3.3.</p> <p>Compliance is checked by inspection.</p>		N/A
4.4.6.4	Protective measures for protective class III equipment		N/A
4.4.6.4.1	General	Class I equipment	N/A
	Protective measures shall be achieved by protective separation by one of the following means: <ul style="list-style-type: none"> • basic insulation and supplementary insulation (double insulation) according to 4.4.3.2 and 4.4.4.5; 		N/A

IEC 62477-1			
Clause	Requirement – Test	Result – Remark	Verdict
	<ul style="list-style-type: none"> reinforced insulation according to 4.4.5.2; electrically protective screening and simple separation according to 4.4.4.7; or a combination of these provisions; used in combination with one of the following means: <ul style="list-style-type: none"> protective impedance according to 4.4.5.4 comprising limitation of discharge energy and of current; or limitation of voltage according to 4.4.3.5. 		
	The protective separation shall be fully and effectively maintained under all conditions of intended use of the PECS.		N/A
4.4.6.4.2	Connection to PELV and SELV circuits		N/A
	<p>If a port is intended for connection of an external PELV or SELV circuit with a higher voltage than DVC As:</p> <ul style="list-style-type: none"> measures to limit the voltage to that of DVC As shall be taken (see Annex A); or basic protection shall be provided. <p>For connectors containing pins with very small contact area (< 1 mm²), the next higher voltage level for DVC As, of Table 5, is permitted. Example: if DVC A1 is DVC As, then DVC A2 is permitted at pins of signal connectors.</p> <p>The connection of external PELV or SELV circuits to an internal circuit is permitted with the following consideration:</p> <ul style="list-style-type: none"> without measures: only if the DVC of the PELV and SELV voltage are lower than or equal to the DVC selected from Table 5 for the internal circuit under consideration; and with measures: if the DVC of the PELV and SELV voltage are higher than the DVC selected from Table 5 for the internal circuit under consideration. <p>The possibility of an addition of the voltages of the circuits under consideration to a higher level under fault conditions shall be considered.</p> <p>For marking, see 6.3.7.1.</p> <p>Consideration needs to be given to factors such as whether the circuits involved are earthed or not, what the voltages involved are, whether or not direct contact with live parts is possible, single faults in either equipment or the interconnections, etc.</p>	The communication port is SELV.	N/A
4.4.7	Insulation		P
4.4.7.1	General		P
4.4.7.1.1	Influencing factors		P
	This subclause gives minimum requirements for insulation, based on the principles of IEC 60664.		P

IEC 62477-1			
Clause	Requirement – Test	Result – Remark	Verdict
	Insulation shall be selected after consideration of the following influences: <ul style="list-style-type: none"> - pollution degree; - overvoltage category; - supply system earthing; - impulse withstand voltage, temporary overvoltage and working voltage; - location of insulation; - type of insulation. 		P
	Verification of insulation shall be made according to 5.2.2.1, 5.2.3.2, 5.2.3.4 and 5.2.3.5.		P
4.4.7.1.2	Pollution degree		P
	Insulation, especially when provided by clearances and creepage distances, is affected by pollution which occurs during the expected lifetime of the PECS. The micro-environmental conditions for insulation shall be applied according to Table 8.	PD3 outside (PD 2 inside)	P
	The pollution degree shall be determined according to the environmental condition for which the product is specified. See Table 18 for selection of pollution degree according to environmental classification of the installation.		P
	The insulation may be determined according to pollution degree 2 if one of the following applies: <ul style="list-style-type: none"> a) instructions are provided with the PECS indicating that it shall be installed in a pollution degree 2 environment; or b) the specific installation application of the PECS is known to be a pollution degree 2 environment; or c) the PECS enclosure or coatings applied within the PECS according to 4.4.7.8.4.2 or 4.4.7.8.6 provide adequate protection against what is expected in pollution degree 3 and 4 (conductive pollution and condensation). 	IP65	P
	The PECS manufacturer shall state in the documentation the pollution degree for which the PECS has been designed.		P
	If operation in a pollution degree 4 environment is required, protection against conductive pollution shall be provided by means of a suitable enclosure.		N/A
4.4.7.1.3	Overvoltage category (OVC)		P
	The measures for reduction of the impulse voltage shall ensure that the temporary overvoltages that could occur are sufficiently limited so that their peak value does not exceed the relevant rated impulse voltage of Table 9 and shall meet the requirement of 4.4.7.2.2, 4.4.7.2.3 and 4.4.7.3 as applicable.		P
	Four categories are considered. <ul style="list-style-type: none"> • Equipment of overvoltage category IV (OVC IV) is 	DC power circuit considered as OVC II.	P

IEC 62477-1			
Clause	Requirement – Test	Result – Remark	Verdict
	<p>for use at the origin of the installation.</p> <ul style="list-style-type: none"> • Equipment of overvoltage category III (OVC III) is equipment in fixed installations and for cases where the reliability and the availability of the equipment are subject to special requirements. • Equipment of overvoltage category II (OVC II) is energy-consuming equipment to be supplied from the fixed installation. • Equipment of overvoltage category I (OVC I) is equipment for connection to circuits in which measures are taken to limit transient overvoltages to an appropriately low level. 		
4.4.7.1.4	Supply earthing systems		N/A
	<p>The following three basic types of system earthing are described in IEC 60364-1.</p> <ul style="list-style-type: none"> • TN system: has one point directly earthed, the accessible conductive parts of the installation being connected to that point by protective conductors. Three types of TN system, TN-C, TN-S and TN-C-S, are defined according to the arrangement of the neutral and protective conductors. • TT system: has one point directly earthed, the accessible conductive parts of the installation being connected to earth electrodes electrically independent of the earth electrodes of the power system. • IT system: has all live parts isolated from earth or one point connected to earth through an impedance, the accessible conductive parts of the installation being earthed independently or collectively to the system earthing. 	Not directly connected to the AC mains.	N/A
4.4.7.1.5	Determination of impulse withstand voltage and temporary overvoltage		P
	<p>Table 9 uses the system voltage (see 4.4.7.1.6) and overvoltage category of the circuit under consideration to determine the impulse withstand voltage. The system voltage is also used to determine the temporary overvoltage.</p> <p>A PECS having more than one input or output shall be evaluated according to the input or output which gives the most severe requirements.</p>		P
4.4.7.1.6	Determination of the system voltage		P
4.4.7.1.6.1	For mains supply	Not directly connected to the AC mains.	N/A
4.4.7.1.6.2	For non-main supply		P
	For PSCS supplied by non-mains a.c. or d.c., the system voltage is the r.m.s. value of the supply voltage between phases.		P
4.4.7.1.7	Components bridging insulation		P

IEC 62477-1			
Clause	Requirement – Test	Result – Remark	Verdict
	Components bridging insulation shall comply with the requirements of the level of insulation (e.g. basic, reinforced, double) they are bridging.		P
4.4.7.2	Insulation to the surroundings		P
4.4.7.2.1	General		P
4.4.7.2.2	Circuits connected to mains supply		N/A
	Insulation between the surroundings and circuits which are connected directly to the mains supply shall be designed according to the impulse withstand voltage, temporary overvoltage, or working voltage, whichever gives the most severe requirement.		N/A
4.4.7.2.3	Circuits connected to Non-mains supply		P
	Insulation between the surroundings and circuits supplied from a non-mains supply shall be designed according to: <ul style="list-style-type: none"> • the impulse withstand voltage determined from Table 9 using the system voltage; • the working voltage; • the temporary overvoltage if known to exist due to the nature of the supply; whichever gives the more severe requirement.		P
	Temporary overvoltage on a non-mains supply shall be determined as follows: <ul style="list-style-type: none"> • Without detailed knowledge of the temporary overvoltage, it shall be according to Table 9. • If the temporary overvoltage is known this value shall be used. 		P
	By the determination of temporary overvoltages on non-mains supply, following situations should be considered: <ul style="list-style-type: none"> • loss of the neutral in a non-mains low-voltage system; • accidental earthing of a non-mains low voltage IT system; and • short circuit in the non-mains low voltage installation. 		P
4.4.7.2.4	Insulation between circuits		P
	Insulation between two circuits shall be designed according to the circuit having the more severe requirement. For the design of simple and protective separation between circuits the insulation shall be designed according to: <ul style="list-style-type: none"> • the circuit having the more severe requirement; or • the working voltage between the circuits; whichever gives the most severe requirement.	Basic insulation between the DC power circuit or AC grid circuit and PE. Reinforced or double insulation between DC power circuit or AC grid circuit and communication circuit.	P

IEC 62477-1			
Clause	Requirement – Test	Result – Remark	Verdict
4.4.7.3	Functional insulation		P
	<p>If the failure of functional insulation does not produce a hazard (electrical, thermal, fire), no specific requirements apply for the dimensioning of functional insulation. In other cases the following requirements apply.</p> <p>Testing is not required, except where the circuit analysis required by 4.2 shows that failure of the insulation could result in a hazard.</p> <p>For parts or circuits that are significantly affected by external transients, functional insulation shall be designed according to the impulse withstand voltage of overvoltage category II, except that overvoltage category III shall be used when the PECS is connected at the origin of the installation.</p> <p>Where measures are provided that reduce transient overvoltages within the circuit from category III to values of category II, or values of category II to values of category I, functional insulation may be designed for the reduced values.</p> <p>Where the circuit characteristics can be shown by testing (see 5.2.3.2) to reduce impulse voltages, functional insulation may be designed for the highest impulse voltage occurring in the circuit during the tests.</p> <p>For parts or circuits that are not significantly affected by external transients, functional insulation shall be designed according to the working voltage across the insulation.</p>		P
4.4.7.4	Clearance distance		P
4.4.7.4.1	Determination	See Table 4.4.7.4	P
	<p>Clearances for functional, basic and supplementary insulation shall be dimensioned according to Table 10 (see Annex D for examples of the evaluation of clearance distances). Interpolation is permitted, when clearance is determined from temporary overvoltage or working voltage.</p> <p>Clearances for reinforced insulation shall be dimensioned to withstand an impulse voltage one step higher than the impulse withstand voltage, or 1,6 times the peak temporary overvoltage or peak working voltage, required for basic insulation.</p> <p>Clearance distances for use in altitudes between 2 000 m and 20 000 m shall be calculated using a correction factor according to Table A.2 of IEC 60664-1:2007, which is reproduced as Table E.1.</p> <p>A correction factor selected from Table F.2 is also used for determination of clearance distances for approximately homogenous fields when frequencies are greater than 30 kHz, as given in Annex F.</p>		P
	Compliance shall be checked by visual inspection (see 5.2.2.1) or by performing the impulse voltage		P

IEC 62477-1			
Clause	Requirement – Test	Result – Remark	Verdict
	test of 5.2.3.2 and the a.c. or d.c. voltage test of 5.2.3.4.		
4.4.7.4.2	Electric field homogeneity		P
	<p>The dimensions in Table 10 correspond to the requirements of an inhomogeneous electric field distribution across the clearance, which are the conditions normally experienced in practice. If a homogeneous electric field distribution is known to exist, the clearance distance for basic or supplementary insulation may be reduced to not less than that required by Table F.2 (Case B) of IEC 60664-1:2007. In this case, however, the impulse voltage test of 5.2.3.2 shall be performed across the considered clearance.</p> <p>If the withstand against steady state voltages, recurring peak or temporary overvoltages according to Table 10 is decisive for the dimensioning of clearance and if these clearances are smaller than the values of Table 10 then an a.c. or d.c. voltage test according to 5.2.3.4 is required. Clearance distances for reinforced insulation shall not be reduced for homogeneous fields.</p>		P
4.4.7.4.3	Clearance to conductive enclosures		P
	The clearance between any non-insulated live part and the walls of a metal enclosure shall be in accordance with 4.4.7.4.1 during and following the deflection tests of 5.2.2.4.2.		P
	Compliance is checked by inspection and by test of 5.2.2.4.2.		P
	If the design clearance distance is at least 12,7 mm and the clearance distance required by 4.4.7.4.1 does not exceed 8 mm, the deflection tests may be omitted.		P
4.4.7.5	Creepage distance		P
4.4.7.5.1	Insulating material groups		P
	Creepage distance requirements for PWBs exposed to pollution degree 3 environmental conditions shall be determined based on Table 11 pollution degree 3 under "Other insulators".		P
	For inorganic insulating materials, for example glass or ceramic, which do not track, the creepage distance may equal the associated clearance distance, as determined from Table 10.		P
4.4.7.5.2	Determination	See Table 4.4.7.5	P
	Creepage distances for functional, basic and supplementary insulation shall be dimensioned according to Table 11. Interpolation is permitted. Creepage distances for reinforced insulation shall be twice the distances required for basic insulation.		P

IEC 62477-1			
Clause	Requirement – Test	Result – Remark	Verdict
	When the creepage distance requirement determined from Table 11 is less than the clearance distance required by 4.4.7.4.1 or the clearance distance determined by impulse testing (see 5.2.3.2), then the creepage distance shall be increased to the clearance distance.		P
	Compliance of creepage distances shall be checked by measurement or inspection (see 5.2.2.1) (see Annex D for examples of the evaluation of creepage distances).		P
4.4.7.6	Coating	No such part	N/A
	A coating may be used to provide insulation, to protect a surface against pollution, and to allow a reduction in creepage and clearance distances (see 4.4.7.8.4.2 and 4.4.7.8.6)		N/A
4.4.7.7	PWB spacings for functional insulation		P
	Spacings for functional insulation shall comply with the requirement of 4.4.7.4 and 4.4.7.5.		P
	<p>Decreased spacings on PWB are permitted when all the following are satisfied:</p> <ul style="list-style-type: none"> • the PWB has flammability rating of V-0 (see IEC 60695-11-10); • the PWB base material has a minimum CTI of 100; • the equipment complies with the PWB short circuit test (see 5.2.4.7). <p>Decreased spacings for components assembled on PWB are permitted when used in:</p> <ul style="list-style-type: none"> • pollution degree 1 or 2 environment; and • not more than overvoltage category I. <p>In this case the manufacture specification may be used.</p> <p>Compliance is checked by inspection and by test of 5.2.4.7 if applicable.</p>		P
4.4.7.8	Solid insulation		P
4.4.7.8.1	General		P
	<p>Materials selected for solid insulation shall be able to withstand the stresses occurring. These include mechanical, electrical, thermal, climatic and chemical stresses which are to be expected in normal use. Insulation materials shall also be resistant to ageing during the expected lifetime of the PECS.</p> <p>Tests shall be performed on components and sub-assemblies using solid insulation, in order to ensure that the insulation performance has not been compromised by the design or manufacturing process.</p>		P
4.4.7.8.2	Material requirements		P

IEC 62477-1			
Clause	Requirement – Test	Result – Remark	Verdict
	The insulating material shall have a CTI of 100 or greater. The insulating material shall be suitable for the maximum temperature it attains as determined by the temperature rise test of 5.2.3.10. Consideration shall be given as to whether or not the insulating material additionally provides mechanical strength and whether or not the part can be subject to impact during use.		P
	The insulating material in contact with live parts higher than DVC As shall comply with: <ul style="list-style-type: none"> • the glow-wire test described in 5.2.5.3 at a test temperature of 850 °C; or • the glow-wire test described in 5.2.5.3, at a lower test temperature, but not less than 550 °C, depending on the classification of the use of the PECS, according to Table A.1 of IEC 60695-2-11:2011; or • the alternative hot wire ignition test of 5.2.5.4. 		P
	Thermoplastic insulating materials used in contact with live parts higher than DVC As or used as part of the enclosure shall comply with the ball pressure test as abnormal heat test according to IEC 60695-10-2.		P
	Where an insulating material is used in a PECS that incorporates switching contacts, and is within 12,7 mm of the contacts, it shall comply with the high current arcing ignition test of 5.2.5.2.		P
	In case the manufacturer of the insulating material provides data to demonstrate compliance with the above requirements no further testing is required. No further evaluation is required when generic materials are used according to Table 12.		P
	Compliance is checked by inspection and by test of 5.2.3.10 and 5.2.5.3 or 5.2.5.2.		P
4.4.7.8.3	Thin sheet or tape material		P
4.4.7.8.3.1	General	See Table 4.4.7.8.3.2	P
	4.4.7.8.3 applies to the use of thin sheet or tape materials in assemblies such as wound components and bus-bars. Insulation consisting of thin (less than 0,75 mm) sheet or tape materials is permitted, provided that it is protected from damage and is not subject to mechanical stress under normal use. Where more than one layer of insulation is used, there is no requirement for all layers to be of the same material. NOTE 1 One layer of insulation tape wound with more than 50 % overlap is considered to constitute two layers. NOTE 2 Basic, supplementary and double insula-		P

IEC 62477-1			
Clause	Requirement – Test	Result – Remark	Verdict
	tion can be applied as a pre-assembled system of thin materials.		
4.4.7.8.3.2	Material thickness $\geq 0,2$ mm		P
	Basic or supplementary insulation shall consist of at least one layer of material, which will meet the requirements of 4.4.7.8.1 and 4.4.7.10.1.		P
	Double insulation shall consist of at least two layers of material, each of which will meet the requirements of 4.4.7.8.1, 4.4.7.10.1, and the partial discharge requirements of 4.4.7.10.2, and both layers together will meet the impulse and a.c. or d.c. voltage requirements of 4.4.7.10.2.		P
	Reinforced insulation shall consist of a single layer of material, which will meet the requirements of 4.4.7.8.1 and 4.4.7.10.2.		P
	NOTE The requirements of this subclause indicate that double insulation can be at least 0,4 mm thick, while reinforced insulation is permitted to be 0,2 mm thick.		P
4.4.7.8.3.3	Material thickness less than 0,2 mm	Not used	N/A
	Basic or supplementary insulation shall consist of at least two layers of material, which will meet the requirements of 4.4.7.8.1 and 4.4.7.10.1.		N/A
	Double insulation shall consist of at least three layers of material. Each layer shall meet the requirements of 4.4.7.8.1 and 4.4.7.10.1, and any two layers together shall meet the requirements of 4.4.7.10.2.		N/A
	Reinforced insulation consisting of a single layer of material is not permitted.		N/A
4.4.7.8.3.4	Compliance		P
	Compliance shall be checked by the tests described in 5.2.3.1 to 5.2.3.5. When a component or sub-assembly makes use of thin sheet insulating materials, it is permitted to perform the tests on the component rather than on the material.		P
4.4.7.8.4	Printed wiring boards (PWBs)		P
4.4.7.8.4.1	General		P
	Insulation between conductor layers in double-sided single-layer PWBs, multi-layer PWBs and metal core PWBs, shall meet the requirements of 4.4.7.8.1. Basic, supplementary, double and reinforced insulation shall meet the appropriate requirements of 4.4.7.10.1 or 4.4.7.10.2. Functional insulation in PWBs shall meet the requirements of 4.4.7.7. For the inner layers of multi-layer PWBs, the insula-		P

IEC 62477-1			
Clause	Requirement – Test	Result – Remark	Verdict
	<p>tion between adjacent tracks on the same layer shall be treated as either:</p> <ul style="list-style-type: none"> • a creepage distance for pollution degree 1 and a clearance as in air (see Example D.14); or • solid insulation, in which case it shall meet the requirements of 4.4.7.8.1 and 4.4.7.10. 		
4.4.7.8.4.2	Use of coating materials	No such part	N/A
	A coating material used to provide functional, basic, supplementary and reinforced insulation shall meet the requirement as specified below.		N/A
	Type 1 protection (as defined in IEC 60664-3) improves the microenvironment of the parts under protection. The clearance and creepage distance of Table 10 and Table 11 for pollution degree 1 apply under the protection. Between two conductive parts, it is a requirement that one or both conductive parts, together with all the spacing between them, are covered by the protection.		N/A
	Type 2 protection is considered to be similar to solid insulation. Under the protection, the requirements for solid insulation specified in 4.4.7.8 are applicable, including the coating material itself, and spacings shall not be less than those specified in Table 1 of IEC 60664-3:2003. The requirements for clearance and creepage in Table 10 and Table 11 do not apply. Between two conductive parts, it is a requirement that both conductive parts, together with the spacing between them, are covered by the protection so that no air gap exists between the protective material, the conductive parts and the printed boards.		N/A
	The coating material used to provide Type 1 and Type 2 protection shall be designed to withstand the stresses anticipated to occur during the expected lifetime of the PECS. A type test on representative PWBs shall be conducted according to Clause 5 of IEC 60664-3:2003. For the cold test (5.7.1 of IEC 60664-3:2003), a temperature of -25 °C shall be used, and for the rapid change of temperature test (5.7.3 of IEC 60664-3:2003): -25 °C to +125 °C. No routine test is required.		N/A
4.4.7.8.5	Wound components		P
	<p>Varnish or enamel insulation of wires shall not be used for basic, supplementary, double or reinforced insulation.</p> <p>Wound components shall meet the requirements of 4.4.7.8.1 and 4.4.7.10.</p> <p>The component itself shall pass the requirements given in 4.4.7.8.1 and 4.4.7.10.2. If the component has reinforced or double insulation, the a.c. or d.c. voltage test of 5.2.3.4 shall be performed as a rou-</p>		P

IEC 62477-1			
Clause	Requirement – Test	Result – Remark	Verdict
	tine test.		
4.4.7.8.6	Potting materials		N/A
	A potting material may be used to provide solid insulation or to act as a coating to protect against pollution.		N/A
	If used as solid insulation, it shall comply with the requirements of 4.4.7.8.1 and 4.4.7.10.		N/A
	If used to protect against pollution, the requirements for Type 1 protection in 4.4.7.8.4.2 apply.		N/A
4.4.7.9	Connection of parts of solid insulation (Cemented joints)		P
	The creepage and clearance path in the presence of a cemented joint between two insulating parts, are determined as follows. <ul style="list-style-type: none"> • Type 1 or type 2 protection as described in 4.4.7.8.4.2 apply. • A cemented joint that is not evaluated as providing protection of type 1 or type 2, is neither considered solid insulation nor to reduce pollution degree. The clearance and creepage distances of Table 10 and Table 11 apply for the pollution degree of the environment around the joint. See 5.2.5.7 for test. 		P
4.4.7.10	Requirements for electrical withstand capability		P
4.4.7.10.1	Basic or supplementary insulation	See Table 4.4.7.10	P
	Test with impulse withstand voltage according to 5.2.3.1		P
	Test with a.c. or d.c. voltage according to 5.2.3.4		P
4.4.7.10.2	Double and reinforced insulation	See Table 4.4.7.10	P
	Double or reinforced insulation shall be tested as follows: <ul style="list-style-type: none"> • Test with impulse withstand voltage according to 5.2.3.2; and • Test with a.c. or d.c. voltage according to 5.2.3.4. 		P
	For solid insulation, the partial discharge test according to 5.2.3.5 shall be performed in addition to the above tests, if the recurring peak working voltage across the insulation is greater than 750 V and the voltage stress on the insulation is greater than 1 kV/mm. The partial discharge test shall be performed as a type test on all components, sub-assemblies and PWB. In addition, a sample test shall be performed if the insulation consists of a single layer of material.		P
	Double insulation shall be designed so that failure of the basic insulation or of the supplementary insulation will not result in reduction of the insulation		P

IEC 62477-1			
Clause	Requirement – Test	Result – Remark	Verdict
	capability of the remaining part of the insulation.		
4.4.7.11	Insulation requirements above 30 kHz		N/A
4.4.8	Compatibility with residual current-operated protective devices		N/A
	<p>To ensure the intended work of an RCD provided by the installation PECS shall satisfy one of the following conditions.</p> <p>a) A Pluggable Type A single-phase PECS, shall be designed so that, under normal and fault conditions any resulting d.c. component of the current in the PE conductor does not exceed the d.c. current withstand requirements in IEC 60755 for RCD of type A.</p> <p>b) For PECS that are Pluggable Type B or intended for permanent connection, d.c. current in the PE conductor is not limited if the information and marking requirements of 6.3.7.4 are complied with.</p>		N/A
	Compliance with RCD provided by the installation shall be checked by simulation or calculation of current in the PE conductor under normal and single fault conditions according to the guideline provided in Annex H.		N/A
4.4.9	Capacitor discharge		N/A
	<p>For protection against shock hazard, capacitors within a PECS shall be discharged to a voltage less than DVC As, or to a residual charge less than 50 μC, after the removal of power from the PECS:</p> <ul style="list-style-type: none"> • For pluggable PECS type A and B the discharge time shall not exceed 1 s or the hazardous live parts shall be protected against direct contact by at least IPXXB (see 4.4.3.3). • For permanently connected PECS the discharge time shall not exceed 5 s. <p>For pluggable PECS type A and B and permanently connected PECS, which do not meet the above requirements, access shall only be possible by means of a tool or key and the information and marking requirements of 6.5.2 apply.</p> <p>Compliance is checked by test of 5.2.3.8.</p>		N/A
4.5	Protection against electrical energy hazards		P
4.5.1	Operator Access Areas		P
4.5.1.1	General		P
	<p>Equipment shall be so designed that there is no risk of electrical energy hazard in operator access areas from accessible circuits by fulfilling requirement of 4.2.</p> <p>A risk of injury due to an electrical energy hazard exists if it is likely that two or more bare parts (one of which may be earthed) between which a hazard-</p>		P

IEC 62477-1			
Clause	Requirement – Test	Result – Remark	Verdict
	<p>ous energy level exists, will be bridged by a metallic object.</p> <p>The likelihood of bridging the parts under consideration is determined by means of the test finger of Figure 1 of IEC 60529:1989, in a straight position. If it is possible to bridge the parts with this test finger, a hazardous energy level shall not exist.</p> <p>Barriers, guards, and similar means preventing unintentional contact may be provided as an alternative to limiting the energy.</p>		
	Compliance is checked by inspection or test of 5.2.2.2.		P
4.5.1.2	Determination of hazardous energy level		P
	<p>A hazardous electrical energy level is considered to exist if:</p> <ul style="list-style-type: none"> • the voltage is 2 V or more; <p>and</p> <ul style="list-style-type: none"> • power available exceeds 240 VA after 60 s; or • the energy exceeds 20 J. <p>Compliance shall be checked with the test in 5.2.3.9 or by calculation.</p>		P
4.5.2	Service Access Areas		P
	Capacitors within a PECS shall be discharged to an energy level less than 20 J, as in 4.5.1.2, within 5 s after the removal of power from the PECS. If this requirement is not achievable for functional or other reasons, the information and marking requirements of 6.5.2 apply.		P
	If the capacitor discharge time cannot be accurately calculated, the discharge time shall be measured.		P
4.6	Protection against fire and thermal hazards		P
4.6.1	Circuits representing a fire hazard		P
	<p>The following types of circuits are considered a fire hazard:</p> <ul style="list-style-type: none"> - circuits directly connected to the mains - circuits that are not directly connected to the mains but exceed the limits for limited power sources in 4.6.5 - components having unenclosed arcing parts 		P
4.6.2	Components representing a fire hazard		P
4.6.2.1	General		P
	Compliance with 4.6.2 and 4.6.3 shall be confirmed by inspection of component and material data sheets and, where necessary, by test.		P
4.6.2.2	Components within a circuit representing a fire hazard		P

IEC 62477-1			
Clause	Requirement – Test	Result – Remark	Verdict
	Inside fire enclosures, materials for components and other parts and all materials in contact with such parts shall comply with flammability class V-2 as classified in IEC 60695-11-10 or flammability class HF-2 as classified in ISO 9772 or better.		P
	<p>The above requirement does not apply to any of the following:</p> <ul style="list-style-type: none"> • electrical components which do not present a fire hazard under abnormal operating conditions when tested according to 5.2.4.6; • materials and components within an enclosure of 0,06 m³ or less, consisting totally of metal and having no ventilation openings, or within a sealed unit containing an inert gas; • electronic components, such as integrated circuit packages, opto-coupler packages, capacitors and other small parts that are mounted on material of flammability class V-1 or better; • wiring, cables and connectors insulated with PVC, TFE, PTFE, FEP, neoprene or polyimide; • the following parts, provided that they are separated from electrical parts (other than insulated wires and cables) which under fault conditions are likely to produce a temperature that could cause ignition, by at least 13 mm of air or by a solid barrier of material of flammability class V-1 or better: <ul style="list-style-type: none"> – other small parts which would contribute negligible fuel to a fire, including, labels, mounting feet, key caps, knobs and the like; – tubing for air or any fluid systems, containers for powders or liquids and foamed plastic parts, provided that they are of flammability class HB. 		P
4.6.2.3	Components within a circuit not representing a fire hazard		P
	For components within a circuit not representing a fire hazard 4.6.2 does not apply.		P
4.6.3	Fire enclosures		P
4.6.3.1	General		P
	<p>Fire enclosures are used to reduce the risk of fire to the environment, independent of the location where they are installed.</p> <p>A fire enclosure shall be provided for all PECS unless:</p> <ul style="list-style-type: none"> • the product committee specifies that a fire enclosure is not required; or • there is an agreement between the user and the manufacturer; or • the PECS is intended to be used only in areas without combustible materials and is marked according to 6.3.5. 	Metal enclosure	P

IEC 62477-1			
Clause	Requirement – Test	Result – Remark	Verdict
4.6.3.2	Flammability of enclosure materials		P
	Materials used for fire enclosures of PECS shall meet the flammability test requirements of 5.2.5.5, except for those portions of the enclosure that enclose only circuits not representing a fire hazard.		N/A
	Materials are considered to comply without test if, in the minimum thickness used, the material is of flammability class 5VA or better, according to IEC 60695-11-20.		N/A
	Metals, ceramic materials, and glass which is heat-resistant tempered, wired or laminated, are considered to comply without test.	Metal enclosure	P
	Materials for components that fill an opening in a fire enclosure shall: <ul style="list-style-type: none"> • be of at least V-1 class material and no larger than 100 mm in any dimension; or • be of at least V-2 class material and either <ul style="list-style-type: none"> – not larger than 25 mm in any dimension; or – not larger than 100 mm in any dimension and located at least 100mm from any part that is a source of fire hazard; or • be of at least V-2 class material and there is a barrier or device(s) that forms a barrier made of a V-0 class material between the part and a source of fire hazard; or • comply with a relevant IEC component standard that includes flammability requirements for components that are intended to form part of, or fill openings in, a fire enclosure. 		N/A
	Polymeric materials that serve as the outer enclosure and have surface area greater than 1 m ² or a single dimension larger than 2 m, shall have a maximum flame spread index of 100 as determined by ASTM E162 or ANSI/ASTM E84.		N/A
	The manufacturer may provide data from the fire enclosure material supplier to demonstrate compliance with the above requirements. In this case, no further testing is required.		N/A
	Compliance shall be checked by visual inspection and, where necessary, by test.		N/A
4.6.3.3	Openings in fire enclosures		N/A
4.6.3.3.1	General		N/A
4.6.3.3.2	Openings in the top and the side of fire enclosures		N/A
	Openings in the top surfaces of fire enclosures shall be designed to prevent an external object falling vertically or at up to 5° from vertically from entering the enclosure in an area that could lead to a fire hazard. This requirement applies to all sides of moveable		N/A

IEC 62477-1			
Clause	Requirement – Test	Result – Remark	Verdict
	equipment with no defined top and bottom, unless top and bottom surfaces can be suitably demonstrated in the installation instructions. Compliance shall be checked by test of 5.2.2.2.		
	Openings in the top surfaces of fire enclosures not located vertically above or within 5° from vertical of a circuit representing a fire hazard as defined in 4.6.1 are not subject to the test of 5.2.2.2 and can be of any construction if the construction prevents access to parts greater than DVC As with the IP3X probe as detailed in 4.4.3.3. Where a portion of the side of a fire enclosure falls within the area traced out by the 5° angle in Figure 6, the limitations in 4.6.3.3.3 regarding openings in bottoms of fire enclosures also apply to this portion of the side. Compliance shall be checked by visual inspection.		N/A
4.6.3.3.3	Openings in the bottom of fire enclosures		N/A
	Compliance is checked by inspection or with the hot flaming oil test in 5.2.5.6, in case the fire enclosure is designed differently than as described in this subclause.		N/A
4.6.3.3.4	Doors of covers in fire enclosures		N/A
	If part of a fire enclosure consists of a door or a cover leading to an operator access area, it shall comply with one of the following requirements: • the door or cover shall be provided with a safety interlock; or • a door or cover, intended to be routinely opened by the user, shall comply with both of the following conditions: – it shall not be removable from other parts of the fire enclosure by the user; and – it shall be provided with a means to keep it closed during normal operation. A door or cover intended only for occasional use by an installer, such as for the installation of accessories, is permitted to be removable provided that the equipment instructions include directions for correct removal and reinstallation of the door or cover. Compliance is checked by inspection.		N/A
4.6.4	Temperature limits		
4.6.4.1	Internal parts	See table 4.6.4	P
	Equipment and its component parts shall not attain temperatures in excess of those in Table 14 when tested in accordance with the ratings of the equipment. Compliance is checked by test of 5.2.3.10.		P
4.6.4.2	Accessible parts	See above	P

IEC 62477-1			
Clause	Requirement – Test	Result – Remark	Verdict
	When surface temperatures of the PECS, close to mounting surfaces, exceed the limit of Table 15, a warning according to 6.3.5 shall be provided.	See above	P
4.6.5	Limited power sources		N/A
	Where a limited power source is required, the source shall comply with Table 16 or Table 17 as applicable.		N/A
	A limited power source shall comply with one of the following requirements: a) the output is inherently limited in compliance with Table 16; or b) a linear or non-linear impedance limits the output in compliance with Table 16. If a positive temperature coefficient device (e.g. PTC) is used, it shall pass the applicable tests specified in IEC 60730-1; or c) a regulating network limits the output in compliance with Table 16, both with and without a single fault in the regulating network; or d) an overcurrent protective device is used and the output is limited in compliance with Table 17.		N/A
	Compliance to determine the maximum available power is checked by test of 5.2.3.9.		N/A
4.7	Protection against mechanical hazards		P
4.7.1	General		P
	Failure of any component within the PECS shall not release sufficient energy to lead to a hazard, for example, expulsion of material into an area occupied by personnel.		P
4.7.2	Specific requirements for liquid cooled PECS		N/A
4.7.2.1	General	Not liquid cooled PECS	N/A
4.7.2.2	Coolant		N/A
	Coolant temperature in operation shall not exceed the limit specified in Table 14.		N/A
	Compliance is checked by inspection and test of 5.2.3.10.		N/A
4.7.2.3	Design requirements		N/A
4.7.2.3.1	General		N/A
	The liquid containment system components shall be compatible with the liquid to be used. Equipment using liquids shall be so constructed that it is unlikely that either a dangerous concentration of these materials or a hazard in the meaning of this standard will be created by condensation, vaporization, leakage, spillage or corrosion during normal operation, storage, filling or emptying.		N/A

IEC 62477-1			
Clause	Requirement – Test	Result – Remark	Verdict
	Compliance is checked by inspection. The flexible hoses should be made of material free of conductive contaminants such as carbon.		
4.7.2.3.2	Corrosion requirements		N/A
	All cooling system components shall be suitable for use with the specified coolant. They shall be corrosion resistant and shall not corrode as a result of prolonged exposure to the coolant and/or air. Compliance is checked by inspection.		N/A
4.7.2.3.3	Tubing, joints and seals		N/A
	Cooling <i>system</i> tubing, joints and seals shall be designed to prevent leakage during excursions of pressure over the life of the equipment. The entire cooling <i>system</i> including tubing shall satisfy the requirements of the hydrostatic pressure test of 5.2.7.		N/A
4.7.2.3.4	Provision for condensation		N/A
	Where internal condensation occurs during normal operation or maintenance, measures shall be taken to prevent degradation of insulation. In those areas where such condensation is expected, clearance and creepage distances of Table 10 and Table 11 shall be evaluated at least for a pollution degree 3 environment (see Table 8), and provision shall be made to prevent accumulation of water (for example by providing a drain). Compliance is checked by inspection.		N/A
4.7.2.3.5	Leakage of coolant		N/A
	During a leakage measures has to ensure that coolant will not result in wetting of live parts or electrical insulation.		N/A
4.7.2.3.6	Loss of coolant		N/A
	Loss of coolant form the cooling system shall not result in thermal hazards, explosion, or shock hazard. The requirements of the Loss of coolant test of 5.4.3.9.4 shall be satisfied.		N/A
4.7.2.3.7	Conductivity of coolant		N/A
	When the coolant is intentionally in contact with live parts (for example non-earthed heatsinks), the conductivity of the coolant shall be continuously monitored and controlled, in order to avoid hazardous current flow through the coolant.		N/A
4.7.2.3.8	Insulation requirements for coolant hoses		N/A
	When the coolant is intentionally in contact with live parts (for example non-earthed heatsinks), the coolant hoses form a part of the insulation system. Depending on the location of the hoses, the requirements of 4.4.7 for functional or simple or protective separation shall be applied where relevant.		N/A

IEC 62477-1			
Clause	Requirement – Test	Result – Remark	Verdict
4.8	Equipment with multiple sources of supply		N/A
	<p>Equipment with more than one supply; design shall be:</p> <ul style="list-style-type: none"> - separate means of connection are provided for different circuits; and - supply plug connections, if any, are not interchangeable if a hazard could be created by incorrect plugging; and - hazards, within the meaning of this standard, shall not be present under normal or single fault conditions due to the presence of multiple sources of supply. Actions such as disconnection or de-energizing of a supply are considered a normal condition. <p>Compliance is checked by the evaluation of 4.2</p>		N/A
	<p>Examples of the types of hazards that should be considered are:</p> <ul style="list-style-type: none"> a) Backfeed prevention – preventing voltage or energy available within the PECS or one of its sources from being fed back to any of the input terminals for another source, either directly or by a leakage path. b) Protection against unintentional islanding. c) Touch current levels may be higher with multiple sources connected simultaneously. d) Hazard resulting from damage to one or more connected sources due to energy from another source, for example the mains. e) Damage to wiring due to currents higher than the wiring is designed for flowing from another source. 		N/A
4.9	Protection against environmental stresses		P
	<p>The manufacturer has to specify the following conditions for operation, storage and transportation according to IEC 60721:</p> <ul style="list-style-type: none"> - Coolant temperature (min/max); - Ambient temperature (min/max); - Humidity (min/max) - Pollution degree; - Vibration; - U.V. resistance; - Over voltage category (OVC); - Altitude for thermal consideration, if rated for operation above 1000 m; - Altitude for insulation coordination considerations, if rated for operation above 2000 m. 		P
	The manufacturer shall state the environmental		P

IEC 62477-1			
Clause	Requirement – Test	Result – Remark	Verdict
	service condition for the PECS according to Table 18.		
4.10	Protection against Sonic Pressure Hazards		P
4.10.1	General		P
4.10.2	Sonic pressure and sound level		P
	If the measured sound pressure exceeds 70 dBA (except that sounds from alarms are not included) the documentation shall provide information regarding the sound level of the equipment.	Less than 70 dBA	P
4.11	Wiring and connections		P
4.11.1	General	Considered	P
	The wiring and connections between parts of the equipment and within each part shall be protected from mechanical damage during installation. The insulation, conductors and routing of all wires of the equipment shall be suitable for the electrical, mechanical, thermal and environmental conditions of use. Conductors which are able to contact each other shall be provided with insulation rated for the DVC requirements of the relevant circuits. The compliance with 4.11.2 to 4.11.8 shall be checked by inspection (see 5.2.1) of the overall construction and datasheets if applicable.		P
4.11.2	Routing		P
	A hole through which insulated wires pass in a sheet metal wall within the enclosure of the equipment shall be provided with a smooth, well-rounded bushing or grommet or shall have smooth, well-rounded surfaces upon which the wires bear to reduce the risk of abrasion of the insulation.		P
	Wires shall be routed away from sharp edges, screw threads, burrs, fins, moving parts, drawers, and similar parts, which abrade the wire insulation. The minimum bend radius specified by the wire manufacturer shall not be violated.		P
	Clamps and guides, either metallic or non-metallic, used for routing stationary internal wiring shall be provided with smooth, well-rounded edges. The clamping action and bearing surface shall be such that abrasion or deformation of the insulation does not occur. If a metal clamp is used for conductors having thermoplastic insulation less than 0,8 mm thick, non-conduction mechanical protection shall be provided.		P
4.11.3	Colour coding		P
	Insulated conductors, other than those which are integral of ribbon cable or multi-cord signal cable, identified by the colour green with or without one or more yellow stripes shall only be used for protective		P

IEC 62477-1			
Clause	Requirement – Test	Result – Remark	Verdict
	bonding.		
4.11.4	Splices and connections		P
	<p>All splices and connections shall be mechanically secured and shall provide electrical continuity. Electrical connections shall be soldered, welded, crimped, or otherwise securely connected. A soldered joint, other than a component on a PWB, shall additionally be mechanically secured.</p> <p><i>NOTE Stranded wire should not be consolidated with solder where secured in a terminal that relies on pressure for contact or equivalent</i></p> <p>When stranded internal wiring is connected to a wire-binding screw, the construction shall be such that loose strands of wire do not contact:</p> <ul style="list-style-type: none"> • other uninsulated live parts not always of the same potential as the wire; • de-energized metal parts. <p>When screw terminal connections are used, the resulting connections may require routine maintenance (tightening). Appropriate reference shall be made in the maintenance manual (see 6.5.1).</p>		P
4.11.5	Accessible connections		P
	<p>In addition to measures given in 4.4.6.4 it shall be ensured that neither insertion error nor polarity reversal of connectors can lead to a voltage on an accessible connection higher than the maximum of DVC As. This applies for example to plug-in sub-assemblies or other plug-in devices which can be plugged in without the use of a tool or key or which are accessible without the use of a tool or key. This does not apply to equipment intended to be installed in restricted access areas.</p> <p>If relevant, non-interchangeability and protection against polarity reversal of connectors, plugs and socket outlets shall be confirmed by inspection and trial insertion.</p>		P
4.11.6	Interconnections between parts of the PSCS		P
	<p>In addition to complying with the requirements given in 4.11.1 to 4.11.5, the means provided for the interconnection between parts of the PECS shall comply with the following requirements or those of 4.11.7.</p> <p>Cable assemblies and flexible cords provided for interconnection between sections of equipment or between units of a system shall be suitable for the service or use involved. Cables shall be protected from physical damage as they leave the enclosure and shall be provided with mechanical strain relief.</p> <p>Misalignment of male and female connectors, insertion of a multipin male connector in a female connector other than the one intended to receive it, and</p>		P

IEC 62477-1			
Clause	Requirement – Test	Result – Remark	Verdict
	<p>other manipulations of parts which are accessible to the operator shall not result in mechanical damage or a risk of thermal hazards, electric shock, or injury to persons.</p> <p>When external interconnecting cables terminate in a plug which mates with a receptacle on the external surface of an enclosure, no risk of electric shock shall exist at accessible contacts of either the plug or receptacle when disconnected.</p> <p><i>NOTE An interlock circuit in the cable to de-energize the accessible contacts whenever an end of the cable is disconnected meets the intent of these requirements.</i></p>		
4.11.7	Supply connections		P
	The connection points provided shall be of appropriate construction to preclude the possibility of loose strands reducing the spacing between conductors when careful attention is paid to installation.		P
4.11.8	Terminals		P
4.11.8.1	Construction requirements		P
	<p>All parts of terminals which maintain contact and carry current shall be of metal having adequate mechanical strength.</p> <p>Terminal connections shall be such that the conductors can be connected by means of screws, springs or other equivalent means so as to ensure that the necessary contact pressure is maintained.</p> <p>Terminals shall be so constructed that the conductors can be clamped between suitable surfaces without any significant damage either to conductors or terminals.</p> <p>Terminals shall not allow the conductors to be displaced or be displaced themselves in a manner detrimental to the operation of equipment and the insulation shall not be reduced below the rated values.</p> <p>The requirements of this subclause are met by using terminals complying with IEC 60947-7-1 or IEC 60947-7-2, as appropriate.</p>		P
4.11.8.2	Connecting capacity		P
	Terminals shall be provided which accommodate the conductors specified in the installation and maintenance manuals (see 6.3.6.4) and cables in accordance with the wiring rules applicable at the installation. The terminals shall meet the temperature rise test of 5.2.3.10.		P
	Information regarding the permitted wire sizes shall be given in the installation manual.		P
4.11.8.3	Connection		P
	Terminals for connection to external conductors		P

IEC 62477-1			
Clause	Requirement – Test	Result – Remark	Verdict
	<p>shall be readily accessible during installation.</p> <p>Sets of terminals for connection to the same input or output shall be grouped together and shall be located in proximity to each other and to the main protective earthing terminal, if any. If the installation instructions provide detail on the proper earthing of the system, the protective earthing terminal need not be placed in proximity to the terminals.</p> <p>Clamping screws and nuts shall not serve to fix any other component although they may hold the terminals in place or prevent them from turning.</p>		
4.11.8.4	Wire bending space for wires 10 mm ² and greater		P
	The distance between a terminal for connection to the main supply, or between major parts of the PECS (for example a transformer), and an obstruction toward which the wire is directed upon leaving the terminal shall be at least that specified in Table 19.		P
4.12	Enclosures		P
4.12.1	General		P
4.12.2	Handles and manual controls		P
	Handles, knobs, grips, levers and the like shall be reliably fixed so that they will not work loose in normal use, if this could result in a hazard. Sealing compounds and the like, other than self-hardening resins, shall not be used to prevent loosening. If handles, knobs and the like are used to indicate the position of switches or similar components, it shall not be possible to fix them in a wrong position if this could result in a hazard.		P
4.12.3	Cast metal		N/A
	<p>Die-cast metal, except at threaded holes for conduit, where a minimum of 6,4 mm thickness is required, shall be:</p> <ul style="list-style-type: none"> • not less than 2,0 mm thick for an area larger than 155 cm² or having any dimension larger than 150 mm; • not less than 1,2 mm thick for an area of 155 cm² or less and having no dimension larger than 150 mm. <p>The area under evaluation may be bounded by reinforcing ribs subdividing a larger area.</p> <p>Malleable iron or permanent-mould cast aluminium, brass, bronze, or zinc, except at threaded holes for conduit, where a minimum of 6,4 mm thickness is required, shall be:</p> <ul style="list-style-type: none"> • at least 2,4 mm thick for an area greater than 155 cm² or having any dimension more than 150 mm; • at least 1,5 mm thick for an area of 155 cm² or less having no dimension more than 150 mm. 		N/A

IEC 62477-1			
Clause	Requirement – Test	Result – Remark	Verdict
	A sand-cast metal enclosure shall be a minimum of 3,0 mm thick except at locations for threaded holes for conduit, where a minimum of 6,4 mm is required.		
4.12.4	Sheet metal		P
4.12.5	Stability		P
	<p>Under conditions of normal use, units and equipment shall not become physically unstable to the degree that they could become a hazard to an operator or to a service person.</p> <p>If units are designed to be fixed together on site and not used individually, the stability of each individual unit is exempt from the requirements of 4.12.5.</p> <p>The requirements of 4.12.5 are not applicable if the installation instructions for a unit specify that the equipment is to be secured to the building structure before operation.</p> <p>Under conditions of operator use, a stabilizing means, if needed, shall be automatic in operation when drawers, doors, etc., are opened.</p> <p>During operations performed by a service person, the stabilizing means, if needed, shall either be automatic in operation, or a marking shall be provided to instruct the service person to deploy the stabilizing means.</p> <p>Compliance is checked by test of 5.2.2.5.</p>		P
5	TEST REQUIRMENTS		P
5.1	General		P
5.1.1	Test objectives and classification		P
5.1.2	Selection of test samples		P
5.1.3	Sequence of tests		P
5.1.4	Earthing conditions		P
5.1.5	General conditions for tests		P
5.1.5.1	Application of tests		P
	Unless otherwise stated, upon conclusion of the tests, the equipment need not be operational.		P
5.1.5.2	Test samples		P
5.1.5.3	Operating parameters for tests		P
5.1.6	Compliance		P
5.1.7	Test overview		P
5.2	Test specifications		P
5.2.1	Visual inspections (type test, sample test and routine test)		P

IEC 62477-1			
Clause	Requirement – Test	Result – Remark	Verdict
	Before type testing, a check shall be made that the PECS delivered for the test is as expected with respect to supply voltage, input and output ranges, etc.		P
5.2.2	Mechanical tests		P
5.2.2.1	Clearances and creepage distance (type test)	See table 5.2.2.1 for details	P
	It shall be verified by measurement or visual inspection that the clearance and creepage distances comply with 4.4.7.4 and 4.4.7.5.		P
	Where this verification is impossible to perform, an impulse voltage test (see 5.2.3.2) shall be performed between the considered circuits.		P
5.2.2.2	Non-accessibility test (type test)		P
	This test is intended to show that live parts, protected by means of enclosures and barriers in compliance with 4.4.3.3, are not accessible.	IP65	P
	This test shall be performed as a type test of the enclosure of a PSCS as specified in IEC 60529 for the enclosure classification for protection against access to hazardous parts.		P
	Except as noted below: •The test probe for IP3X shall not penetrate the top surface of the enclosure when probed from the vertical direction $\pm 5^\circ$ only.		N/A
5.2.2.3	Ingress protection test (IP rating) (type test)		P
	The claimed IP rating of the enclosure shall be verified. This test shall be performed as a type test of the enclosure of a PSCS as specified in IEC 60529 for the enclosure classification.	IP rating of the enclosure: IP65	P
5.2.2.4	Enclosure integrity test (type test)		P
5.2.2.4.1	General		P
	The integrity tests apply to PSCS, and also where PSCS are intended for operation without a further enclosure in restricted access areas. After completion of the integrity test, the PSCS shall pass the tests of 5.2.3.2 and 5.2.3.4 and shall be inspected to confirm that:		P
	- no degradation of any safety-relevant component of the PSCS has occurred.		P
	- live parts have not become accessible (see 4.4.3.3).		P
	- enclosures show no cracks or openings which could cause a hazard.		P
	- clearances are not less than their minimum permitted values and other insulation is undamaged.		P
	- barriers have not been damaged or loosened.		P

IEC 62477-1			
Clause	Requirement – Test	Result – Remark	Verdict
	- no moving parts which could cause a hazard are exposed.		P
	The integrity tests shall be performed at the worst case point on representative accessible face(s) of the enclosure.		P
	The PSCS is not required to be operational after testing and the enclosure may be deformed to such an extent that its original IP rating is not maintained.		P
5.2.2.4.2	Deflection test (type test)		P
5.2.2.4.2.1	General		P
	If requested by 4.12.1 the test in 5.2.2.4.2.2 and 5.2.2.4.2.3 applies, for metallic enclosure, as applicable.		P
5.2.2.4.2.2	Steady force test, 30 N		P
5.2.2.4.2.3	Steady force test, 250 N		P
5.2.2.4.3	Impact test (type test)	Metal enclosure	N/A
5.2.2.4.4	Drop		N/A
	Transportable equipment ≤ 18 kg Drop three times from 1000 mm on a horizontal surface at locations where they provide the most adverse results.	No transportable equipment	N/A
5.2.2.4.5	Stress relief	Metal enclosure	N/A
5.2.2.5	Stability test		P
5.2.2.6	Wall or ceiling mounted equipment		N/A
5.2.2.7	Handles and manual controls securement		P
5.2.3	Electrical tests		P
5.2.3.1	General		P
	The electrical tests described in 5.2.3.2 to 5.2.3.5 are applicable to basic, supplementary and reinforced insulation. Before performing these tests, preconditioning according to 5.2.6.3.1 and 5.2.6.3.2 is required.		P
	When performing electrical and preconditioning tests, the preferred procedure is to test the entire equipment; however it is acceptable to test the components or sub-assemblies providing the basic and reinforced insulation. When components or sub-assemblies are tested, test conditions shall simulate the least favourable conditions occurring inside the equipment at the place of installation.		P
5.2.3.2	Impulse voltage test (type test and sample test)	See Table 4.4.7.10	P
5.2.3.3	Alternative to Impulse voltage test (type test and sample test)		N/A

IEC 62477-1			
Clause	Requirement – Test	Result – Remark	Verdict
	An a.c. or d.c. voltage test according to 5.2.3.4 may be used as an alternative method to the impulse voltage test of 5.2.3.2.		N/A
	For an a.c. voltage test the peak value of the a.c. test voltage shall be equal to the impulse test of Table 25 and applied for three cycles of the a.c. test voltage.		N/A
	For a d.c. voltage test the average value of the d.c. test voltage shall be equal to the impulse test voltage of Table 25 and applied three times for 10 ms in each polarity.		N/A
	See IEC60664-1 clause 6.1.2.2.2 for further information.		N/A
5.2.3.4	A.C. or d.c. voltage test (type test and routine test)		P
5.2.3.4.1	Purpose of test		P
	The test is used to verify that the clearances and solid insulation of components and of assembled PSCS has adequate dielectric strength to resist temporary overvoltage conditions.		P
5.2.3.4.2	Value and type of test voltage		P
	The values of the test voltage for circuits connected to mains supply are determined from column 2 or 3 of Table 26. The voltage test shall be performed with a sinusoidal voltage at 50 Hz or 60 Hz. If the circuit contains capacitors the test may be performed with a d.c. voltage of a value equal to the peak value of the specified a.c. voltage.		P
5.2.3.4.3	Performing the voltage test	See table 4.4.7.10	P
	a) Test (1) between accessible conductive part (connected to earth) and each circuit sequentially (except DVC As circuits). Test voltage according to Table 26, or Table 27, column 2, corresponding to voltage of considered circuit under test. Test (2) between accessible surface (non-conductive or conductive but not connected to earth) and each circuit sequentially (except DVC As circuits). Test voltage according to Table 26 or Table 27, column 3 (for type test) or column 2 (for routine test), corresponding to voltage of considered circuit under test.		P
	b) Test between each considered circuit sequentially and the other adjacent circuits connected together. Test voltage according to Table 26 or Table 27, column 2, corresponding to voltage of considered circuit under test.		P

IEC 62477-1			
Clause	Requirement – Test	Result – Remark	Verdict
	c) Test between DVC As circuit and each adjacent circuit sequentially. Test voltage according to Table 26 or Table 27, column 3 (for type test) or column 2 (for routine test), corresponding to the circuit with the higher voltage. Either the adjacent circuit or the DVC As circuit may be earthed for this test. It is necessary to test functional insulation between PELV and SELV circuits, but it is not necessary to test functional insulation between adjacent PELV or adjacent SELV circuits.		P
5.2.3.4.4	Duration of the a.c. or d.c. voltage test		P
	The duration of the test shall be at least 60 s for the type test and 1 s for the routine test. The test voltage may be applied with increasing and/or decreasing ramp voltage but the full voltage shall be maintained for 60 s and 1 s respectively for type and routine tests.		P
5.2.3.4.5	Verification of the a.c. or d.c. voltage test		P
	The test is successfully passed if no electrical breakdown occurs during the test.		P
5.2.3.5	Partial discharge test (type test, sample test)		N/A
	The partial discharge test shall confirm that the solid insulation (see 4.4.7.8) used in components and subassemblies for protective separation of electrical circuits remains partial-discharge-free within the specified voltage range (see Table 28).		N/A
	This test shall be performed as a type test and a sample test. It may be omitted for insulating materials which are not degraded by partial discharge, for example ceramics. The partial discharge inception and extinction voltage are influenced by climatic factors (e.g. temperature and moisture), equipment self-heating, and manufacturing tolerance. These influencing variables can be significant under certain conditions and shall therefore be taken into account during type testing.		N/A
5.2.3.6	Protective impedance (type test and routine test)		N/A
	A type test shall be performed to verify that the current through a protective impedance under normal operating or single-fault conditions does not exceed the values given in 4.4.3.4. The test shall be performed using the circuit of IEC 60990:1999, Figure 4. NOTE IEC 60990 states that the use of a single network for the measurement of a.c. combined with d.c. has not been investigated, but no suggestion is made for measurement in such cases. The value of the protective impedance shall be veri-		N/A

IEC 62477-1			
Clause	Requirement – Test	Result – Remark	Verdict
	ified as a routine test.		
5.2.3.7	Touch current measurement (type test)		N/A
	The touch current shall be measured to determine if the measures of protection need not be taken (see 4.4.4.3.3). The PECS shall be set up in an insulated state without any connection to the earth and shall be operated at rated voltage. Under these conditions, the touch current shall be measured between the means of connection for the PE conductor and the PE conductor itself with the test circuit of Figure 4 of IEC 60990:1999.		N/A
	• For a PSCS to be connected to an earthed neutral system, the neutral of the mains of the test site shall be directly connected to the protective earthing conductor.		N/A
	• For a PSCS to be connected to an earthed neutral system, the neutral shall be connected through a resistance of 1 k Ω to the protective earthing conductor which shall be connected to each input phase in turn. The highest value will be taken as the definitive result.		N/A
	• For a PSCS to be connected to a corner earthed system, the protective earthing conductor shall be connected to each input phase in turn. The highest value will be taken as the definitive result.		N/A
	• For a PSCS with a particular earthing system, this system shall operate as intended during the test.		N/A
	• If a PSCS is intended to be connected to more than one system network, each of these different system networks (or the worst-case, if that can be determined) shall be used to make the touch current measurement.		N/A
5.2.3.8	Capacitor discharge (type test)		N/A
	The capacitor discharge time as required by 4.4.3.4 may be verified by a type test and/or by calculation taking into account the relevant tolerances.		N/A
5.2.3.9	Limited power source test (type test)		N/A
	When required by 4.6.5 a limited power circuit shall be tested as below, with the equipment operating under normal operating conditions. In case the limited power source requirement depends on overcurrent protective device(s), the device(s) shall be short-circuited. With the equipment operating under normal operating conditions, a variable resistive load is connected to the parts under consideration and adjusted to obtain a level required limited VA power. Further adjustment is made, if necessary, to maintain the limited VA power for a period specified by 4.6.5. A variable resistive load is connected to the circuit		N/A

IEC 62477-1			
Clause	Requirement – Test	Result – Remark	Verdict
	<p>under consideration and adjusted to obtain the limit of apparent power as indicated in Table 16 or Table 17, as applicable. Further adjustment is made, if necessary, to maintain the limit of apparent power for the time period indicated in Table 16 or Table 17, as applicable.</p> <p>The test is passed, if after the test period the available apparent power does not exceed the limits indicated in Table 16 or Table 17, as applicable.</p> <p>In case the limited power source requirement depends on overcurrent protective device(s), the current rating of at least one of the protective device(s) in the current path shall not exceed the limit in Table 17.</p>		
5.2.3.10	Temperature rise test (type test)		P
	If possible the PECS must operate in the worst conditions of the rated power and the output current.		P
	Equipment, in which the heating or cooling quantity depends on the temperature, the temperature measurement must be carried out under the most unfavourable conditions of ambient temperature within the range specified by the manufacturer.		P
	The PECS shall be tested with at least 1,2 m of wire attached to each field wiring terminal. The wire shall be of the smallest size intended to be connected to the PECS as specified by the manufacturer for installation. When there is only provision for the connection of bus-bars to the PECS, they shall be of the minimum size intended to be connected to the PECS as specified by the manufacturer, and they shall be at least 1,2 m in length.		P
	The test shall be maintained until thermal stabilization has been reached. That is, when three successive readings, taken at intervals of 10 % of the previously elapsed duration of the test and not less than 10 min. intervals, indicate no change in temperature, defined as ± 1 °C between any of the three successive readings, with respect to the ambient temperature.		P
	The temperature of an electrical insulation (other than that of windings) is measured on the surface of the insulation at a point close to the heat source, if a failure of this insulation could cause a hazard. If temperatures of windings are measured by the thermocouple method, the thermocouple shall be located on the surface of the winding assuming the hottest part due to surrounding heat emitting components. See also notes in Table 14.		P
	The maximum temperature attained shall be corrected to the rated ambient temperature of the PSCS by adding the difference between the ambi-		P

IEC 62477-1			
Clause	Requirement – Test	Result – Remark	Verdict
	ent temperature during the test and the maximum rated ambient temperature.		
	No corrected temperature shall exceed the rated temperature of the material or component measured.		P
	During the test, thermal cut-out, overload detection functions and devices shall not operate.		P
5.2.3.11	Protective bonding tests (type tests and routine test)		P
5.2.3.11.1	General		P
	<p>Each conductive accessible part under consideration shall be tested separately, to determine if the protective equipotential bonding path for that part is adequate to withstand the test current that the bonding path may be subjected to under fault conditions.</p> <p>The circuit under consideration shall be selected from amongst those circuits adjacent to the accessible part under consideration and separated from it by only basic or functional insulation.</p> <p>All of these selected circuits have to be analysed regarding prospective short circuit current and the associated protective element(s):</p> <ul style="list-style-type: none"> - If the circuit under consideration exceeds the 5 s disconnection time requirement of IEC 60364-4-41, the protective equipotential bonding impedance test of 5.2.3.11.2 and the protective equipotential bonding short circuit test of 5.2.3.11.3 have to be performed. - If the circuit under consideration meets the 5 s disconnection time requirement of IEC 60364-4-41, the protective equipotential bonding short circuit test of 5.2.3.11.3 has to be performed. - If the circuit under consideration meets the disconnection time requirement of IEC 60364-4-41:2005, Table 41.1, as applicable, depending on the earthing system of the installation, no type test is required. 		P
	For pluggable equipment type A only the protective equipotential bonding impedance test of 5.2.3.11.2 have to be performed.		N/A
5.2.3.11.2	Protective bonding impedance test (type test)		P
5.2.3.11.2.1	Test Conditions		P
	Where required by 4.4.4.2.2 and 5.2.3.11.2.1, the impedance of protective equipotential bonding means shall be checked by passing a test current through the bond for a period of time. The test current is based on the rating of the overcurrent pro-		P

IEC 62477-1			
Clause	Requirement – Test	Result – Remark	Verdict
	<p>tection for the equipment or part of the equipment under consideration, as follows:</p> <ul style="list-style-type: none"> • for pluggable equipment type A, the overcurrent protective device is that provided external to the equipment (for example, in the building wiring, in the mains plug or in an equipment rack); • for pluggable equipment type B and permanently connected equipment, the maximum rating of the overcurrent protective device specified in the equipment installation instructions to be provided external to the equipment; • the rating of the provided overcurrent device for a circuit or part of the equipment for which an overcurrent protective device is provided as part of the equipment. 		
5.2.3.11.2.2	Test current, duration, and acceptance criteria:		P
	a) For PECS with an overcurrent protective device rating of 16 A or less, this test may be omitted, if an impedance not exceeding 0,1 Ω can be demonstrated.		N/A
	b) As an alternative to Table 29, where the time-current characteristic of the overcurrent protective device that limits the fault current in the protective equipotential bonding means is known because the device is either provided in the equipment or fully specified in the installation instructions, the test duration may be based on that specific device's time-current characteristic. The tests are conducted for a duration corresponding to the 200 % current value on the time-current characteristic.		P
	c) For PECS with an overcurrent protective device rating of more than 460 A, calculations or simulations according to IEC 60949 shall be used to show the ability of the prospective short circuit current to fulfil the requirements. The protective equipotential bonding continuity routine test of 5.2.3.11.4 shall be performed to show that the impedance of the protective equipotential bonding means during and at the end of the test shall not exceed the expected value.		N/A
	Acceptance criteria: The test current is 200 % of the overcurrent protective device rating and the duration of the test is as shown in Table 29. The voltage drop in the protective equipotential bonding means, during and at the end of the test, shall not exceed DVC As, as determined from Table 2 and Table 5 with respect to the accessible surface of the enclosure.		P
	After the tests, visual inspection shall show no damage to the <i>protective equipotential bonding</i> means.		P

IEC 62477-1			
Clause	Requirement – Test	Result – Remark	Verdict
5.2.3.11.3	Protective bonding short circuit withstand test (type test)		N/A
	As required by 5.2.3.11.2.1, the short circuit test in 5.2.4.3 shall be performed to ensure that protective bonding has the ability to withstand the prospective short circuit current that it may be subjected to under fault conditions.		N/A
	The testing shall include an individual test of the protective bonding path for each conductive accessible part unless analysis shows that the short circuit withstand capability of the path is adequate, or that the results of one combination are representative of the anticipated results of another combination.		N/A
5.2.3.11.4	Protective bonding continuity test (routine test)		P
5.2.4	Abnormal operation and simulated faults tests		P
5.2.4.1	General	See table 4.2 and 4.3	P
5.2.4.2	Pass criteria		P
	<p>As a result of the abnormal operation tests, the PSCS shall comply with the following:</p> <ul style="list-style-type: none"> • there shall be no emission of flame, burning particles or molten metal; • the surgical cotton indicator shall not have ignited; • the earth connection and protective bonding of the PSCS shall not have opened; • doors and cover shall remain in place; • during and after the test, accessible DVC As, SELV and PELV circuits and accessible conductive parts shall not exhibit voltages greater than the time dependent voltages of Figure 1, Figure 2 or Figure 3, as appropriate and shall be separated from live parts at voltages greater than DVC As with at least basic insulation. Compliance shall be checked by the a.c./d.c. insulation test of 5.2.3.4 for basic insulation; • during and after the test, live parts at voltages greater than DVC As shall not become accessible. • components, e.g. busbar supports, used for the mounting of live parts not break away from their initial position, (IEC 62477-1:2012/AMD1:2016) • no conductor shall get pulled out of its terminal connector. (IEC 62477-1:2012/AMD1:2016) 		P
	The PSCS is not required to be operational after testing and it is possible that the enclosure can be-		P

IEC 62477-1			
Clause	Requirement – Test	Result – Remark	Verdict
	come deformed. Overcurrent protection integral to the PECS, or required to be used with the PECS, is allowed to open.		
5.2.4.3	Protective bonding short circuit withstand test (type test)		N/A
5.2.4.3.1	General		N/A
	When required by 5.2.3.11.2.1, a protective bonding path shall be subjected to the following short-circuit withstand test.		N/A
5.2.4.3.2	Test conditions		N/A
	The equipment under test shall be supplied with power and the output port shall be operating as intended in 5.2.4.1 prior to closing the switching means that applied will be more severe.		N/A
	The protective bonding short circuit test shall be performed with the PSCS working with light load, unless analysis shows that higher short circuit currents are available under higher loading conditions.		N/A
	A new sample may be used for each short-circuit test.		N/A
5.2.4.3.3	Protective equipotential bonding short-circuit test method		N/A
5.2.4.3.4	Pass criteria		N/A
5.2.4.4	Output Short-circuit test (type test)		P
5.2.4.4.1	Load conditions		P
	The short circuit test shall be performed with the PSCS at full load or light load whichever creates the more severe condition.		P
5.2.4.4.2	Short-circuit test method		P
	In addition to determining compliance with the criteria of 5.2.4.2, this test is used to determine the output short circuit current rating of the port under consideration, in accordance with 4.3.2.3. An oscilloscope or other suitable instrument shall be used to measure the peak current during the test, and to measure or calculate the r.m.s. value of the current.		P
	The value(s) to be recorded and to be provided with the PECS instructions, in accordance with 6.2, are the peak current, and the highest of the r.m.s. current values measured or calculated over a time period as follows: a) for a.c. signals, three cycles of the nominal a.c. frequency for the port under consideration, in which case the value is to be stated as the 3-cycle r.m.s. value; b) for all signals, the duration of the short circuit from the time the short circuit is applied, until the time the short circuit current is interrupted by a protective device or other mechanism, in which case		P

IEC 62477-1			
Clause	Requirement – Test	Result – Remark	Verdict
	<p>the value stated is to include the r.m.s. value and the time period in seconds;</p> <p>c) for short circuit tests that result in a continuous non-zero value, the steady-state r.m.s. value, in which case the value is to be stated as a continuous r.m.s value.</p> <p>For PECS with internal short circuit protection according to 4.3.2.3, which protects the output port within some few μs, the requirements in a), b) and c) are not applicable.</p>		
5.2.4.5	Output Overload test (type test)		N/A
5.2.4.6	Breakdown of components test (type test)		P
5.2.4.6.1	Load conditions	See table 4.2 and 4.3	P
	The breakdown of a component, identified as a result of the circuit analysis of 4.2, shall be tested with the PSCS at full load or light load whichever creates the more severe condition.		P
5.2.4.6.2	Application of short-circuit or open-circuit		P
	The short circuit shall be applied with cable of a cross-section appropriate for the current that normally flows through the component, but no less than 2.5 mm ² . The length of the loop shall be as short as practical to perform the test. Short circuits and open circuits are applied using an appropriate switching device.		P
	Each identified component shall be subjected to only one breakdown of components test unless both open- and short-circuit failure modes are likely in that component.		P
5.2.4.6.3	Test sequence		P
	For the Breakdown of components test, identified components shall be short-circuited or open-circuited, whichever creates the worst hazard, one at a time.		P
5.2.4.7	PWB short-circuit test (type test)		N/A
	On PWBs, functional insulation provided by spacings which are less than those specified in Table 10 and Table 11 (see 4.4.7.7) shall be type tested as described below.		N/A
	The decreased spacings shall be short-circuited one at a time, on representative samples, and the short-circuit shall be maintained until no further damage occurs.		N/A
5.2.4.8	Loss of phase (type test)		N/A
	A multi-phase PSCS shall be operated with each line (including neutral, if used) disconnected in turn at the input. The test shall be performed by disconnecting one line with the power conversion equip-		N/A

IEC 62477-1			
Clause	Requirement – Test	Result – Remark	Verdict
	ment operating at its maximum normal load and shall be repeated by initially energizing the device with on lead disconnected.		
	The test shall continue until terminated by a protective mechanism, a component failure occurs, or the temperature stabilizes.		N/A
	This particular requirement may be simulated for PSCS with rated input current greater than 500 A.		N/A
5.2.4.9	Cooling failure tests (type test)		N/A
5.2.4.9.1	General and pass criteria		N/A
	For PSCS having a combination of cooling mechanisms, all relevant tests shall be performed. It is not necessary to perform the tests simultaneously. The test shall continue, - until the temperature stabilizes, in which case the temperature limits of 4.6.4.2 apply; or - until terminated by a protective mechanism or a component failure occurs, in which case the temperature limits of 4.6.4.2 may be exceeded by not more than 5°C. If this is not possible a warning statement shall be provided in the user documentation.	No cooling system	N/A
	NOTE The temperature increase of 5 °C with regard to the steady state limits reflect the spread of the burn threshold given in IEC Guide 117.		N/A
5.2.4.9.2	Inoperative blower motor		N/A
	A PSCS having forced ventilation shall be operated at rated load with fan or blower motor or motors made inoperative, singly or in combination from a single fault, by physically preventing their rotation.		N/A
5.2.4.9.3	Clogged filter		N/A
	Enclosed PSCS having filtered ventilation openings shall be operated with the openings blocked to represent clogged filters. The test shall be performed initially with the ventilation openings blocked 50 %. The test shall be repeated under full blocked condition.		N/A
5.2.4.9.4	Loss of coolant		N/A
	A liquid cooled PSCS shall be operated at rated load. Loss of coolant shall be simulated by draining the coolant, blocking the flow or disabling the system coolant pump.		N/A
	If the PSCS is shut down due to the operation of a thermal device located inside the coolant, then the test shall be repeated with the coolant drained out of the system.		N/A
	NOTE: It is presumed that the thermal device will		N/A

IEC 62477-1			
Clause	Requirement – Test	Result – Remark	Verdict
	be inoperative if not surrounded by coolant liquid.		
5.2.4.10	Short time withstand current (I_{cw}) test (type test) (IEC 62477-1:2012/AMD1:2016)		N/A
5.2.4.10.1	General (IEC 62477-1:2012/AMD1:2016)		N/A
	As required in 4.3.5, the short time withstand current test performed as a type test to verify the safety of the PECS. (IEC 62477-1:2012/AMD1:2016)		N/A
	Short-circuits are applied in the PECS at locations based on the evaluation in 4.2 so that terminals and other parts in the fault current path are being exposed to the short-circuit current. (IEC 62477-1:2012/AMD1:2016)		N/A
5.2.4.10.2	Short time withstand current test method (IEC 62477-1:2012/AMD1:2016)		N/A
	The input mains supply port terminals provided with a cable with a cross-section as specified for the installation. (IEC 62477-1:2012/AMD1:2016)		N/A
	If a switching device is used to initiate the short-circuit or switch the power to the PECS, it not limit the test current. (IEC 62477-1:2012/AMD1:2016)		N/A
	The complete length of the cable (forth and back) approximately 2 m, unless this length is insufficient, in which case the length as short as practical to perform the test. (IEC 62477-1:2012/AMD1:2016)		N/A
	The testing include individual tests for each input mains supply port. (IEC 62477-1:2012/AMD1:2016)		N/A
	The worst case combination of terminals (including neutral and earth) subjected to a short-circuit test. (IEC 62477-1:2012/AMD1:2016)		N/A
	The PECS can be tested unenergized and not operating as intended prior to the short-circuit withstand test, if it can be shown that the test result is not affected. (IEC 62477-1:2012/AMD1:2016)		N/A
	A new sample used for each short-circuit test. (IEC 62477-1:2012/AMD1:2016)		N/A
	Table 37 lists the a.c. current test method as a minimum requirement for PECS. (IEC 62477-1:2012/AMD1:2016)		N/A
5.2.4.10.3	Compliance criteria (IEC 62477-1:2012/AMD1:2016)		N/A
	As a result of the short time withstand current (I_{cw}) test, the PECS comply with the compliance criteria of 5.2.4.2. (IEC 62477-1:2012/AMD1:2016)		N/A
5.2.5	Material tests		N/A
5.2.5.1	General		N/A
	When requested by 4.4.7.8.2, the manufacturer shall test the flammability properties of the materials used for insulating purposes, as defined in 5.2.5.2, 5.2.5.3 and 5.2.5.4.		N/A

IEC 62477-1			
Clause	Requirement – Test	Result – Remark	Verdict
	When requested by 4.6.3.2 the manufacturer shall test the flammability properties of the materials used for fire enclosure, as defined in 5.2.5.5.		
5.2.5.2	High current arcing ignition test (type test)		N/A
5.2.5.3	Glow-wire test (type test)		P
	The glow-wire test shall be made under the conditions specified in 4.4.7.8.2 according to IEC 60695-2-10 and IEC 60695-2-13.		P
5.2.5.4	Hot wire ignition test (type test – alternative to Glow-wire test)		N/A
5.2.5.5	Flammability test (type test)		N/A
5.2.5.6	Flaming oil test (type test)		N/A
5.2.5.7	Test of cemented joints (type test)		N/A
	<p>When required by 4.4.7.9 representative samples of cemented joints providing protection of type 1 or type 2 as defined in IEC 60664-3:2003 shall be tested as a type test as follows.</p> <p>The samples shall be subjected to the conditioning procedure specified in 5.7 of IEC 60664-3:2003, using the following parameters: for the cold test (5.7.1), a temperature of -25 °C shall be used, and for the rapid change of temperature test (5.7.3): – 25 °C to +125 °C.</p> <p>After the conditioning the samples shall pass the following tests in the prescribed order:</p> <ol style="list-style-type: none"> The mechanical strength of the joint shall be evaluated by loading the joint using the forces anticipated to be present under normal conditions. There shall be no separation of the parts. The insulation resistance between the conductive parts separated by the joint shall be measured according to 5.8.3 of IEC 60664-3:2003. Cemented joints shall be treated as to be thin sheet material and shall be tested according 4.4.7.8.3. The sectioning of the joint shall not show any cracks, voids or separation. 		N/A
5.2.6	Environmental tests (type test)		P
5.2.6.1	General		P
	Compliance is shown by conducting test of 5.2.6.3, 5.2.6.4, 5.2.6.5 and 5.2.6.6 according to Table 30 as applicable for the environmental conditions specified by the manufacture.		P
5.2.6.2	Acceptance criteria		P
	The following acceptance criteria shall be satisfied:		P

IEC 62477-1			
Clause	Requirement – Test	Result – Remark	Verdict
	<ul style="list-style-type: none"> - no degradation of any safety-relevant component of the PSCS; - no potentially hazardous behaviour of the PSCS during the test; - no sign of component overheating; - no live part shall become accessible; - no cracks in the enclosure and no damaged or loose insulators; - pass routine a.c. or d.c. voltage test 5.2.3.4; - pass protective bonding test 5.2.3.11.2; - no potentially hazardous behaviour when the PSCS is operated following the test. 		
5.2.6.3	Climatic tests		P
5.2.6.3.1	Dry heat test (steady state)		P
	To prove the ability of components and equipment to be operated, transported or stored at high temperatures the dry heat (steady state) test shall be performed according to the conditions specified in Table 31.		P
5.2.6.3.2	Damp heat test (steady state)		P
	To prove the resistance to humidity, the PSCS shall be subjected to a Damp heat test (steady state) according to Table 32.		P
5.2.6.4	Vibration test (type test)		P
	<p>To verify the mechanical vibration strength the PECS in combination with its installation shall be evaluated by:</p> <ul style="list-style-type: none"> a) tests defined in this section according to the conditions specified in Table 33; or b) calculation or simulation based on tests, as defined in this section, on a representative model of PECS. <p>For PSCS with a mass more than 100 kg, this test may be performed on sub-assemblies.</p> <p>NOTE For large equipment, the possibility of using a shock test as an alternative to a vibration test is under consideration.</p>		P
5.2.6.5	Salt mist (type test)		N/A
	<p>To verify the resistance against salt mist, the PECS in combination with its installation shall be evaluated by tests defined in this section according to the conditions specified in Table 34.</p> <p>For PSCS with a mass more than 100 kg, this test may be performed on sub-assemblies.</p>	PECS is not intended to be used in the environmental condition of salt mist, which specified by the manufacturer.	N/A
5.2.6.6	Dust and sand (type test)		N/A
	To verify the mechanical strength against dust and	PECS is not intended to be	N/A

IEC 62477-1			
Clause	Requirement – Test	Result – Remark	Verdict
	sand the PECS in combination with its installation shall be evaluated by tests defined in this section under the conditions specified in Table 35. For PSCS with a mass more than 100 kg, this test may be performed on sub-assemblies.	used in the environmental condition of dust and sand, which specified by the manufacturer.	
5.2.7	Hydrostatic pressure (type test and routine test)		N/A
	For type tests, the pressure inside the cooling system of a liquid cooled PSCS (see 4.7.2.3.3) shall be increased at a gradual rate until a pressure relief mechanism (if provided) operates, or until a pressure of twice the operating value or 1,5 times the maximum pressure rating of the system is achieved, whichever is the greater. <i>NOTE: for the purpose of this test the coolant pump may be disabled.</i> For routine tests, the pressure shall be increased to the maximum pressure rating of the system. The pressure shall be maintained for at least one minute. There shall be no thermal, shock, or other hazard resulting from the test. There shall be no significant leakage of coolant or loss of pressure during the test, other than from a pressure relief mechanism during a type test. After the hydrostatic pressure type test the PSCS shall pass the a.c. or d.c. voltage test 5.2.3.4.		N/A
6	INFORMATION AND MARKING REQUIREMENTS		P
6.1	General		P
6.2	Information for selection (IEC 62477-1:2012/AMD1:2016)		P
	- the name or trademark of the manufacturer, supplier or importer;		P
	- catalogue number or equivalent;		P
	- electrical ratings for each power port: <ul style="list-style-type: none"> - maximum nominal input voltage; - maximum nominal output voltage; - maximum nominal output current or nominal output power rating; - maximum nominal input current rms for dimensioning overload protective elements and wiring; - number of phases (e.g. 3 a.c.); - nominal frequency range (e.g. 50 Hz to 60 Hz); - protective class (I, II, III); 		P
	- the type of electrical supply system (e.g. TN, IT) to which the PECS may be connected;		P
	- short-circuit current rating(s) in terms of:		P

IEC 62477-1			
Clause	Requirement – Test	Result – Remark	Verdict
	<ul style="list-style-type: none"> - conditional short-circuit current (I_{cc}) and minimum required prospective short-circuit current $I_{cp, mr}$ and the characteristics of the short-circuit protective device according to clause 4.3.2.2, or - rated short time withstand current (I_{cw}), duration and the rated peak withstand current (I_{pk}) according to 4.3.5. 		
	- output short-circuit current in accordance with 4.3.2.3;		P
	- supply requirements of the load (if applicable);		P
	- liquid coolant type and design pressure for liquid cooled PECS;		N/A
	- IP rating for enclosure;		P
	- operating and storage environment;		P
	- reference(s) to relevant standard(s) for manufacture, test, or use;		P
	- reference to instructions for installation, use and maintenance.		P
6.3	Information for installation and commissioning		P
6.3.1	General		P
6.3.2	Mechanical considerations		P
	<p>The following drawings shall be prepared by the manufacturer:</p> <ul style="list-style-type: none"> - Dimensional drawing, including mass information - Mounting drawing 		P
6.3.3	Environment		P
	In accordance with 4.9 the following environmental conditions shall be specified, for operation, transportation and storage:		P
	Climatic (temperature, humidity, altitude, pollution, ultra-violet light, etc.)		P
	Mechanical (vibration, shock, drop, topple, etc.)		P
	Electrical (overvoltage category)		P
6.3.4	Handling and mounting		P
	<p>In order to prevent injury or damage, the installation documents shall include warnings of any hazards which can be experienced during installation. Where necessary, instructions shall be provided for:</p> <ul style="list-style-type: none"> - packing and unpacking; - moving; - lifting; 		P

IEC 62477-1			
Clause	Requirement – Test	Result – Remark	Verdict
	<ul style="list-style-type: none"> - strength and rigidity of mounting surface; - fastening; - provision of adequate access for operation, adjustment and maintenance. 		
6.3.5	Enclosure temperature		P
	When surface temperatures of the PECS, close to mounting surfaces, exceed the limit of 4.6.4.2, the installation manual shall contain a warning to consider the combustibility of the mounting surface.		P
	Where required by 4.6.3.1, the following marking shall appear on the PECS and in the installation instructions: "suitable for mounting on concrete or other non-combustible surfaces only".		P
6.3.6	Connections		P
6.3.6.1	General		P
	Information shall be provided to enable the installer to make safe electrical connection to the PSCS. This shall include information for protection against hazards (for example, electric shock or availability of energy) that may be encountered during installation, operation or maintenance.		P
6.3.6.2	Interconnection and wiring diagrams		P
	The installation and maintenance manuals shall include details of all necessary connections, together with a suggested interconnection diagram.		P
6.3.6.3	Conductor (cable) selection		P
	The Installation manual shall define the voltage and current levels for all connections to the PSCS, together with cable insulation requirements. These shall be worst-case values, taking into account overcurrent and overload conditions and the possible effects of non-sinusoidal currents.		P
6.3.6.4	Terminal capacity and identification		P
	The installation and maintenance manuals shall indicate the range of acceptable conductor sizes and types (solid or stranded) for all terminals, and also the maximum number of conductors which can simultaneously be connected.		P
	For field wiring terminals, the manuals shall specify the requirements for tightening torque values and also the insulation temperature rating requirements for the conductor or cable.		P
	The identification of all field wiring terminals shall be marked on the PSCS, either directly or by label attached close to the terminals.		P
	The installation and maintenance manuals identify all external terminals relating to circuits protected by		P

IEC 62477-1			
Clause	Requirement – Test	Result – Remark	Verdict
	one of the methods of 4.4.6.4.		
6.3.7	Protection requirements		P
6.3.7.1	Accessible parts circuits		P
	The installation, users and maintenance manuals shall identify any accessible parts at voltages greater than DVC As, and shall describe the insulation and separation provisions required for protection.		P
	The manuals shall also indicate the precautions to be taken to ensure that the safety of DVC As connections maintained during installation.		P
	Where a hazard is present after the removal of a cover, a warning label shall be placed on the equipment. The label shall be visible before the cover is removed.		P
	The manual of a PSCS state the maximum voltage allowed to be connected to each port.		P
	The manuals provide instructions for the use of PELF circuits within a zone of equipotential bonding.		P
6.3.7.2	Type of electrical supply system	DC circuit	N/A
	The installation manual or the PECS specify requirements for safe earthing including the permitted earthing system of the installation (see 4.4.7.1.4)		N/A
	The unacceptable earthing systems shall be indicated as: - not permitted; or - with modification of values and/or safety levels which shall be quantified through type test.		N/A
6.3.7.3	Protective class		P
6.3.7.3.1	General		P
	The installation manual of the PECS shall declare the protective class specified for the PECS and the product shall be marked according to the requirement of 6.3.7.3.2, 6.3.7.3.3, and 6.3.7.3.4.		P
6.3.7.3.2	Protective class I equipment		P
	Terminals for connection of the PE conductor shall be clearly and indelibly marked with one or more of the following:		P
	The symbol IEC 60417-5019 (2011-01)		P
	With the letters PE		P
	The colour coding green or green-yellow		P
6.3.7.3.3	Protective class II equipment	Class I equipment	N/A
	Equipment of protective class II shall be marked with symbol IEC 60417-5172 (2011-01) (see Annex C). Where such equipment has provision for the connection of an earthing conductor for functional reasons		N/A

IEC 62477-1			
Clause	Requirement – Test	Result – Remark	Verdict
	(see 4.4.6.3) it shall be marked with symbol IEC 60417-5018 (2011-01) (see Annex C).		
6.3.7.3.4	Protective class III equipment		N/A
	No marking is required on the product.		N/A
6.3.7.4	Touch current marking		N/A
	Where the touch current in the PE conductor exceeds the limits given in 4.4.4.3.3., this shall be stated in the installation and maintenance manuals. In addition, a warning symbol ISO 7010- W001 (2011-06) (see Annex C) shall be placed on the product, and a notice shall be provided in the installation manual to instruct the user that the minimum size of the PE conductor shall comply with the local safety regulations for high PE conductor current equipment.		N/A
6.3.7.5	Compatibility with RCD marking		N/A
	The installation and maintenance manuals shall indicate compatibility with RCDs (see 4.4.8). When 4.4.8 b) applies, a caution notice and the symbol ISO 7010-W001 (2011-06) (see Annex C) shall be provided in the user manual, and the symbol shall be placed on the product. The caution notice shall be the following or equivalent: “This product can cause a d.c. current in the PE conductor. Where a residual current-operated protective device (RCD) is used for protection against electrical shock, only an RCD of Type B is allowed on the supply side of this product.” (See 6.4.3 for general requirements for labels, signs and signals.)		N/A
6.3.7.6	Cable and connection		N/A
	Any particular cable and connection requirements shall be identified in the installation and maintenance manuals.		N/A
6.3.7.7	External protection devices		N/A
	Where external devices are necessary to protect against hazards, the installation manual shall specify the required characteristics (see also 5.2.4 and 4.3.2.1)		N/A
6.3.8	Commissioning		N/A
	If commissioning tests are necessary to ensure the electrical and thermal safety of a PSCS, information to support these tests shall be provided for each part of the PSCS. This information can depend on the specific installation, and close cooperation between manufacturer, installer, and user can be required. Commissioning information shall include references to hazards that might be encountered during commissioning, for example those mentioned in 6.4. and 6.5.		N/A
6.4	Information for use		P

IEC 62477-1			
Clause	Requirement – Test	Result – Remark	Verdict
6.4.1	General		P
	The user's manual shall include all information regarding the safe operation of the PSCS. In particular, it shall identify any hazardous materials and risks of electrical shock, overheating, misuse of the PSCS.		P
	The manual should also indicate any hazards which can result from reasonably foreseeable misuse of the PSCS.		P
6.4.2	Adjustment		P
	The user's manual shall give details of all safety-relevant adjustments intended for the user. The identification or function of each control or indicating device and fuse shall be marked adjacent to the item. Where it is not possible to do this on the product, the information shall be provided pictorially in the manual.		P
	Maintenance adjustments may also be described in this manual, but shall be made clear that they should only be made by qualified personnel.		P
	Clear warnings shall be provided where excessive adjustment could lead to a hazardous state of the PSCS.		P
	Any special equipment necessary for making adjustments shall be specified and described.		P
6.4.3	Labels, signs and signals		P
6.4.3.1	General		P
	<p>Labelling shall be in accordance with good ergonomic principles so that notices, controls, indications, test facilities, fuses, etc., are sensibly placed and logically grouped to facilitate correct and unambiguous identification.</p> <p>All safety related equipment labels shall be located so as to be visible after installation or readily visible by opening a door or removing a cover.</p> <p>Where a symbol is used, the information provided with the PSCS shall contain an explanation of the symbol and its meaning.</p>		P
	<p>Labels shall:</p> <ul style="list-style-type: none"> • wherever possible, use international symbols as given by ISO 3864-1, ISO 7000 or IEC 60417; • if no international symbol is available, be worded in an appropriate language or in a language associated with a particular technical field; • be concise and unambiguous; • be conspicuous, legible and durable; • state the hazards involved and give ways in which risks can be reduced. 		P
	When instructing the person(s) concerned as to		P

IEC 62477-1			
Clause	Requirement – Test	Result – Remark	Verdict
	<ul style="list-style-type: none"> • what to avoid: the wording should include “no”, “do not”, or “prohibited”; • what to do: the wording should include “shall”, or “must”; • the nature of the hazard: the wording should include “caution”, “warning”, or “danger”, as appropriate; • the nature of safe conditions: the wording should include the noun appropriate to the safety device. 		
	Safety signs shall comply with ISO 3864-1.		P
	<p>The signal words indicated hereinafter shall be used and the following hierarchy respected:</p> <ul style="list-style-type: none"> • DANGER to call attention to a high risk, for example: “High voltage”. • WARNING to call attention to a medium risk, for example: “This surface can be hot.” • CAUTION to call attention to a low risk, for example: “Some of the tests specified in this standard involve the use of processes imposing risks on persons concerned.” <p>Danger, warning and caution markings on the PECS shall be prefixed with the word “DANGER”, “WARNING”, or “CAUTION” as appropriate in letters not less than 3,2 mm high. The remaining letters of such markings shall be not less than 1,6 mm high.</p>		P
6.4.3.2	Isolators		N/A
	Where an isolating device is not intended to interrupt load current, a warning shall state: DO NOT OPEN UNDER LOAD.		N/A
	The following requirements apply to any supply isolating device which does not disconnect all sources of power to the PSCS.		N/A
	If the isolating device is mounted in an equipment enclosure with the operating handle externally operable, a warning label shall be provided adjacent to the operating handle stating that it does not disconnect all power to the PSCS.		N/A
	Where a control circuit disconnecter can be confused with power circuit disconnectors due to size or location, a warning label shall be provided adjacent to the operating handle of the control disconnecter stating that it does not disconnect all power to the PSCS.		N/A
6.4.3.3	Visual and audible signals		P
	Visual signals such as flashing lights, and audible signals such as sirens, may be used to warn of an impending hazardous event such as the driven equipment start-up and shall be identified.		P

IEC 62477-1			
Clause	Requirement – Test	Result – Remark	Verdict
	<p>It is essential that these signals:</p> <ul style="list-style-type: none"> - are unambiguous; - can be clearly perceived and differentiated from all other signals used; - can be clearly recognized by the user; - are emitted before the occurrence of the hazardous event. <p>It is recommended that higher frequency flashing lights be used for information.</p> <p>Note: IEC 60073 provides guidance on recommended flashing rates and on/off ratios.</p>		
6.4.3.4	Hot surfaces		P
	Where required by 4.6.4.2 the warning symbol W017 of ISO 7010 shall be marked on or adjacent to parts exceeding the touch temperature limits of Table 15.		P
6.4.3.5	Equipment marking		P
	<p>The Identification of each control or indicating device and fuse shall be marked adjacent to the item. Replaceable fuses shall be marked with their rating and time characteristics. Where it is not possible to do this on the product, the information shall be provided pictorially in the manual.</p> <p>Appropriate identification shall be marked on or adjacent to each movable connector.</p> <p>Test points shall be individually marked with the circuit diagram reference.</p> <p>The polarity of any polarized devices shall be marked adjacent to the device.</p> <p>The diagram reference and if possible the function shall be marked adjacent to each pre-set control in a position where it is clearly visible while the adjustment is being made.</p>		P
6.5	Information for maintenance		P
6.5.1	General		P
	The PECS shall be marked with the date code, or serial number from which the date of manufacture can be determined.		P
	Safety information shall be provided in the installation and maintenance manuals including appropriate, the following:		P
	• Preventive maintenance procedures and schedules		P
	• Safety precautions during maintenance		P
	• Location of live parts that can be accessible during maintenance (for example, when covers are removed)		P
	• Adjustment procedures		P

IEC 62477-1			
Clause	Requirement – Test	Result – Remark	Verdict
	• Subassembly and component repair and replacement procedures		P
	• Any other relevant information		P
6.5.2	Capacitor discharge		N/A
	When the requirements 4.4.9 are not met, the warning symbol W012 of ISO 7010 and an indication of the discharge time (for example, 45 s, 5 min) shall be placed in a clearly visible position on the enclosure, the capacitor protective barrier, or at a point close to the capacitor(s) concerned (depending on the construction). The symbol shall be explained and the time required for the capacitors to discharge after the removal of the power from the PSCS shall be stated in the installation and maintenance manuals.		N/A
6.5.3	Auto restart/bypass connection		N/A
	If a PSCS can be configured to provide automatic restart or bypass connection, the installation, user and maintenance manuals shall contain appropriate warning statements.		N/A
	A PSCS which is set to provide automatic restart or bypass connection, after the removal of power, shall be clearly identified at the installation.		N/A
6.5.4	Other hazards		P
	The manufacturer shall identify any components and materials of a PSCS which require special procedures to prevent hazards.		P
6.5.5	Equipment with multiple sources of supply		N/A
	In accordance with 4.8, where there is more than one source of supply energizing the PSCS, information shall be provided to indicate which disconnect device or devices are required to be operated in order to completely isolate the equipment.		N/A

IEC 62477-1			
Clause	Requirement – Test	Result – Remark	Verdict

4		TABLE: mains supply electrical data in normal condition			P
Condition	Voltage [V]	Cell Voltage [V]	Current [A]	Temperature [°C]	
Charge	747.5	3.626	50	25.0	
Discharge	601.9	2.890	50	25.0	
Condition	Voltage [V]	Cell Voltage [V]	Current [A]	Temperature [°C]	
Charge	718.9	3.625	5	50.0	
Discharge	612.3	2.891	5	50.0	

Note(s): The most unfavourable measured value is recorded in the table.

4.2 to 4.3		TABLE: Abnormal operation and simulated faults tests					P
		ambient temperature (°C)			25.0		—
No.	component No.	fault	test voltage (V)	test time	fuse No.	input current (A)	result
Cell Voltage sampling of BSCU							
1.	Cell 15& Cell 16(CON2)	S-C	102.4	10min	-	-	Battery module fuse blown, the slave detects that the cell voltage is too low. Then send the error to master unit. The master unit switches off the relays.
2.	R141 (Cell1)	O-C	102.4	10min	-	-	The slave unit can't sample the voltage of this cell. Then send the error to master unit. The master unit switches off the relays.
3.	R82 (Cell7)	S-C	102.4	10min	-	-	The system operates normally.
4.	C108	S-C	102.4	10min	--	-	The slave detects that the voltage dropout voltage of cell15 and cell16 is too large. The system operates normally.
Power Supply of BSCU							
5.	R74 (Supply input)	O-C	102.4	10min	--	-	The power supply can't work. The system shut down. The relays switch off.
Temperature sampling of BSCU							
6.	R92 (NTC1)	S-C	102.4	10min	--	-	The system operates normally.
7.	C121 (NTC2)	O-C	102.4	10min	--	-	The system operates normally.

IEC 62477-1							
Clause	Requirement – Test					Result – Remark	Verdict
8.	R87 (NTC3)	O-C					The temperature continues to rise, and after rising to a certain value (before temperature protection), the temperature point will be rejected, and the system will remain normal
Communication of BSCU							
9.	R128	O-C	102.4	10min	--	-	No communication between the slave unit and the master unit. The master unit switches off the relays.
10.	R144	O-C	102.4	10min	--	-	No communication between the slave unit and the master unit. The master unit switches off the relays.
Power Supply of BMS							
11.	F2	O-C	102.4	10min	--	-	The power supply can't work. The system shut down. The relays switch off.
12.	C2 (+12V)	S-C	102.4	10min	--	-	The power supply can't work. The system shut down. The relays switch off.
13.	C20 (5V)	S-C	102.4	10min	--	-	The power supply can't work. The system shut down. The relays switch off.
14.	C18 (3.3V)	S-C	102.4	10min	--	-	The power supply can't work. The system shut down. The relays switch off.
15.	R193 (feedback)	O-C	102.4	10min	--	-	The system operates normally.
16.	C100 (12V)	S-C	102.4	10min	--	-	The power supply can't work. The system shut down. The relays switch off.
Current Sampling of Hall							
17.	CN1 PIN2&PIN3	S-C	102.4	10min	--	-	The master unit detects the discharge overcurrent error and switches off the relays.
MCU of BMS							
18.	Y1 Oscillator	O-C	102.4	10min	--	-	The master MCU can't work. The slave MCU switches off the relays.
19.	Y1 Oscillator	S-C	102.4	10min	--	-	The master MCU can't work. The slave MCU switches off the relays.
20.	Y1 Oscillator	50%F	102.4	10min	--	-	The frequency of crystal oscillator is changed, so The system can't start up.

IEC 62477-1							
Clause	Requirement – Test			Result – Remark			Verdict
21.	Y1 oscillator	200%F	102.4	10min	--	-	The frequency of crystal oscillator is changed, so The system can't start up.
Communication of BMS							
22.	R92 (to BSCU)	O-C	102.4	10min	--	-	No communication between the slave unit and the master unit. The master unit switches off the relays.
23.	U10 PIN3&PIN4	S-C	102.4	10min	--	-	No communication between the slave MCU and the master MCU. The slave MCU switches off the relays.
24.	R105 (CAN)	O-C	102.4	10min	--	-	No communication between the slave MCU and the master MCU. The slave MCU switches off the relays.
Relay Control of BMS							
25.	R188 (INPUT+)	O-C	102.4	10min	--	-	The relays switches off. The master unit report the relays fault.
26.	R15 (INPUT-)	O-C	102.4	10min	--	-	The relays switches off. The master unit report the relays fault.
27.	R14(Feedback)	O-C	102.4	10min	--	-	The system operates normally.
28.	R265 (control)	O-C	102.4	10min	--	-	The power supply can't work. The system shut down. The relays switch off.
29.	RELAY1	S-C, then simulate the fault of V/I/T	102.4	10min	--	-	The circuit is open by the main relay of P-.
30.	RELAY2	S-C, then simulate the fault of V/I/T	102.4	10min	--	-	The circuit is open by the main relay of P+.
Voltage Sampling							
31.	R141	O-C	102.4	10min	--	-	The master unit cannot detect the bus voltage. The master unit switches off the relays.
Insulation							
32.	R137	O-C	102.4	10min	--	-	The system displays a self-checking fault after powering on. The main control unit cannot turn on the machine normally.
Current Sampling							
33.	R3	O-C	102.4	10min	--	-	The master unit detects the charge overcurrent error and switches off the relays.

IEC 62477-1			
Clause	Requirement – Test	Result – Remark	Verdict

Note(s):

- 1) In fault column, short circuit (s-c), open circuit (o-c). The unit passed electric strength test after single fault test above.
- 2) Test was conducted on representative battery system, model: T-BAT HS7.2.

4.6.4, 5.2.3.10	TABLE: heating temperature rise measurements		P
	test voltage (V)	90Vdc to 116Vdc	—
	Testing Conditions	Charging and discharging	
	Temperature of part/at:	Max temperature measured (°C)	Max temperature corrected to max. operate temperature (°C)
			Temperature Limit (°C)
BMS control box (TBMS-MCS0800)			
	Surface of cabinet enclosure	50.4	55.4
	Start Button	50.3	55.3
	Interconnection cable (BAT+ / BAT-) to PCS	52.2	57.2
	Terminal block (BAT+ / BAT-)	51.1	56.1
	Internal leading wire (BAT+ to AK) of battery power circuit	58.6	63.6
	Circuit Breaker (AK) (internal body)	52.4	57.4
	Pre-change Resistor	51.8	56.8
	Relay (KM1)	72	77.0
	Relay (KM2)	71.6	76.6
	Current transducer (HCT1) on SHUNT Board	52.5	57.5
	Terminal block (B+ / B-)	50.1	55.1
	Interconnection cable (B+ / B-) to Battery module	50.3	55.3
BMS Board in Control box			
	Terminal block (J1)	52.5	57.5
	X capacitor (CX2)	53.3	58.3
	MOSFET (Q13) on PCB	59.3	64.3
	Transformer (TX1) winding	61.6	66.6
	Transformer (TX1) bobbin	61	66.0
	Optical coupler (U16)	58.1	63.1
	Isolation IC (U10)	57.2	62.2
	Optical coupler (U19)	53.7	58.7
	Optical coupler (U28)	52.1	57.1

IEC 62477-1			
Clause	Requirement – Test	Result – Remark	Verdict
Isolation IC (U21)	53	58.0	100
TX2	52.3	57.3	110
Master MCU (U1) on PCB	57.8	62.8	130
FUSE	53.4	58.4	105
Battery Module (TP-HS36)			
Surface of Enclosure	50.3	55.3	65
Fuse body	51.1	56.1	130
Insulator of Fuse	51.1	56.1	90
Internal leading wire (Fuse to Battery module)	51.2	56.2	85
Insulation cover sheet of Module	51.3	56.3	85
Cell 13	51.7	56.7	60
Cell 4	51.6	56.6	60
BSCU 16S UV Board			
Slave MCU (U3)	53.9	58.9	130 (PCB)
Transformer (T1)	50.8	55.8	100
Ambient	48.0	53.0	-
Note(s): Test was conducted with representative model T-BAT HS7.2. Charging and discharging current is 5A, test ambient temperature is 48°C and corrected to 53°C, because the DUT will derating when ambient temperature exceed 45°C.			

IEC 62477-1			
Clause	Requirement – Test	Result – Remark	Verdict

4.6.4, 5.2.3.10	TABLE: heating temperature rise measurements		P
	test voltage (V)	90Vdc to 116Vdc	—
Testing Conditions Temperature of part/at:	Charging and discharging		Temperature Limit (°C)
	Max temperature measured (°C)	Max temperature corrected to max. operate temperature (°C)	
BMS control box (TBMS-MCS0800)			
Surface of cabinet enclosure	25.4	45.4	65
Start Button	26.4	46.4	75
Interconnection cable (BAT+ / BAT-) to PCS	45.4	65.4	85
Terminal block (BAT+ / BAT-)	34.6	54.6	75
Internal leading wire (BAT+ to AK) of battery power circuit	44.9	64.9	85
Circuit Breaker (AK) (internal body)	46.4	66.4	80
Pre-charge Resistor	32.0	52.0	85
Relay (KM1)	40.1	60.1	85
Relay (KM2)	41.5	61.5	85
Current transducer (HCT1) on SHUNT Board	48.1	68.1	85
Terminal block (B+ / B-)	40.9	60.9	75
Interconnection cable (B+ / B-) to Battery module	50.2	70.2	85
BMS Board in Control box			
Terminal block (J1)	33.9	53.9	85
X capacitor (CX2)	33.3	53.3	85
MOSFET (Q13) on PCB	36.0	56.0	130
Transformer (TX1) winding	38.0	58.0	110
Transformer (TX1) bobbin	37.7	57.7	125
Optical coupler (U16)	36.4	56.4	100
Isolation IC (U10)	35.7	55.7	100
Optical coupler (U19)	32.1	52.1	100
Optical coupler (U28)	31.1	51.1	100
Isolation IC (U21)	33.2	53.2	100
TX2	31.1	51.1	110
Master MCU (U1) on PCB	35.8	55.8	130
FUSE	82.0	102.0	105

IEC 62477-1			
Clause	Requirement – Test	Result – Remark	Verdict

Battery Module (TP-HS36)			
Surface of Enclosure	28.7	48.7	65
Fuse body	84.2	104.2	130
Insulator of Fuse	51.7	71.7	90
Internal leading wire (Fuse to Battery module)	53.9	73.9	85
Insulation cover sheet of Module	35.0	55.0	85
Cell 13	47.5	67.5*	60
Cell 4	47.6	67.6*	60
BSCU 16S UV Board			
Slave MCU (U3)	39.4	59.4	130
Transformer (T1)	37.9	57.9	100
Ambient	25.0	45.0	-
Note(s): *: The cell surface temperature will not exceed 60, because the battery will stop operate when the NTC near cells exceed 55°C. The test was conducted with max charging and discharging current 50A on representative model T-BAT HS7.2. Test ambient temperature is 25°C and will corrected to 45°C, because the DUT will derating when ambient temperature exceed 45°C.			

IEC 62477-1							
Clause	Requirement – Test	Result – Remark					Verdict
4.4.7.4 to 4.4.7.5, 5.2.2.1	TABLE: clearance and creepage distance measurements						P
Clearance cl and creepage distance dcr at/of:	Impulse / system voltage [V]	U r.m.s. [V]	required cl [mm]	cl [mm]	required dcr [mm]	dcr [mm]	
Master BMS Unit (TBMS-MCS0800)							
Battery power circuit +/- to Enclosure (PE): BI	4000	800	3.42	See below	8.0	See below	
- at P+ / P- connector to mounting screw of Enclosure	--	--	--	4.8	--	9.0	
- at B+ / B- connector to mounting screw of Enclosure	--	--	--	6.37	--	15.0	
- at all PCBA to Enclosure (at fixing pillar): BI	--	--	--	20.0	--	20.0	
SHUNT Board							
Shunt circuit to Enclosure (at fixing pillar)	4000	800	3.42	See below	4.0	See below	
BMS MAIN CONTROL Board							
Battery power supply circuit BAT+ to BAT-: FI	4000	800	3.42	See below	4.0	See below	
- at terminal block (J1)	--	--	--	8.3	--	8.3	
Battery power supply circuit to PE: BI	4000	800	3.42	See below	4.0	See below	
- at Y capacitor (CY5, CY7)	--	--	--	7.0	--	7.0	
Battery power supply circuit to MCU Control circuit: BI	4000	800	3.42	See below	4.0	See below	
Battery power supply circuit to sampling circuit: BI	4000	800	3.42	See below	4.0	See below	
- at isolation IC (U10)	--	--	--	7.4	--	7.4	
- at Optical coupler (U6, U16)	--	--	--	8.7	--	8.7	
- at Optical coupler (U23)	--	--	--	7.4	--	7.4	
Battery power supply circuit to 12V/3.3V5V aux. power supply circuit: BI	4000	800	3.42	See below	4.0	See below	
- at Optical coupler (U15)	--	--	--	8.7	--	8.7	
- at Y capacitor (CY1)	--	--	--	7	--	7	
- at Transformer (TX1 pin 2/3/4, 7/8 to pin 10/11, 12/13, 16/17)	--	--	--	15.0	--	15.0	
MCU Control circuit to Communication circuit: SI	4000	800	3.42	See below	4.0	See below	
- at Y capacitor (CY2)	--	--	--	7	--	7	

IEC 62477-1						
Clause	Requirement – Test			Result – Remark		Verdict
- at Optical coupler (U18,U19)	--	--	--	7.8	--	7.8
- at Transformer (TX2)	--	--	--	11.5	--	11.5
- at isolation IC (U33)	--	--	--	7.4	--	7.4
- at isolation IC (U21)	--	--	--	9.0	--	9.0
- at isolation IC (U34)	--	--	--	7.4	--	7.4
- at Optical coupler (U26, U27, U28)	--	--	--	8.6	--	8.6
Battery Module (TP-HS36)						
Battery power circuit +/- to Enclosure (PE): BI	4000	800	3.42	See below	8.0	See below
- at B+ / B- connector to mounting screw of Enclosure	See above	See above	See above	15.0	See above	15.0
- at BSCU 16S UV Board to Enclosure (at fixing pillar): BI	--	--	--	10.0	--	10.0
BSCU 16S UV Board						
Sampling circuit to Enclosure (PE): BI	4000	800	3.42	See below	4.0	See below
- at Screw hole	--	--	--	6.0	--	6.0
Sampling circuit to communication circuit: RI	6000	800	6.27	See below	8.0	See below
- at Transformer (T1)	--	--	--	11.5	--	11.5
Note(s): Battery circuit = O.V.C II, PD = PD2, Altitude ≤ 3000m (correction factor:1.14), MG = IIIa/IIIb assumed.						

4.4.7.10	TABLE: electric strength measurements, impulse voltage test and partial discharge test				P
test voltage applied between:	test voltage (V)	impulse withstand voltage (V)	partial discharge extinction voltage (V)	result	
Battery + to Protective Earthing Terminal	DC 2120	4000	--	No electrical breakdown	
Battery - to Protective Earthing Terminal	DC 2120	4000	--	No electrical breakdown	
Battery circuit + to Communication circuit	DC 4240	6000	--	No electrical breakdown	
Battery circuit - to Communication circuit	DC 4240	6000	--	No electrical breakdown	
Note(s):					

Appendix 1 EN 62477-1/A11

Clause	Requirement – Test	Result – Remark	Verdict
--------	--------------------	-----------------	---------

FOREWORD			P
	<p>This document (EN 62477-1:2012/A11:2014) has been prepared by CLC/TC 22X "Power electronics".</p> <p>The aim behind this Amendment is to link EN 62477-1:2012 to the Low Voltage Directive 2006/95/EC, further to a CLC/TC 22X request, approved by the Technical Board by the decision D146/C017.</p> <p>In addition, a recent Technical Board decision (D147/C061), confirmed that EN 62477-1:2012 partially supersedes EN 50178:1997.</p> <p>This standard covers the Principle Elements of the Safety Objectives for Electrical Equipment Designed for Use within Certain Voltage Limits (LVD - 2006/95/EC).</p>		P

Appendix 2 EN 62477-1/A12

Clause	Requirement – Test	Result – Remark	Verdict
ZZ	ANNEX ZZ (INFORMATIVE) RELATIONSHIP BETWEEN THIS EUROPEAN STANDARD AND THE SAFETY OBJECTIVES OF DIRECTIVE 2014/35/EU [2014 OJ L96] AIMED TO BE COVERED		P
	<p>This European standard has been prepared under a Commission's standardisation request relating to harmonised standards in the field of the Low Voltage Directive, M/511, to provide one voluntary means of conforming to safety objectives of Directive 2014/35/EU of the European Parliament and of the Council of 26 February 2014 on the harmonisation of the laws of the Member States relating to the making available on the market of electrical equipment designed for use within certain voltage limits [2014 OJ L96].</p> <p>Once this standard is cited in the Official Journal of the European Union under that Directive, compliance with the normative clauses of this standard given in Table ZZ.1 confers, within the limits of the scope of this standard, a presumption of conformity with the corresponding safety objectives of that Directive, and associated EFTA regulations.</p>		P